



EKSKLUZYWNE POKRYCIA DACHOWE

Skrócona
instrukcja
montażu
panelu
dachowego
Alex, Oskar

www.regamet.pl



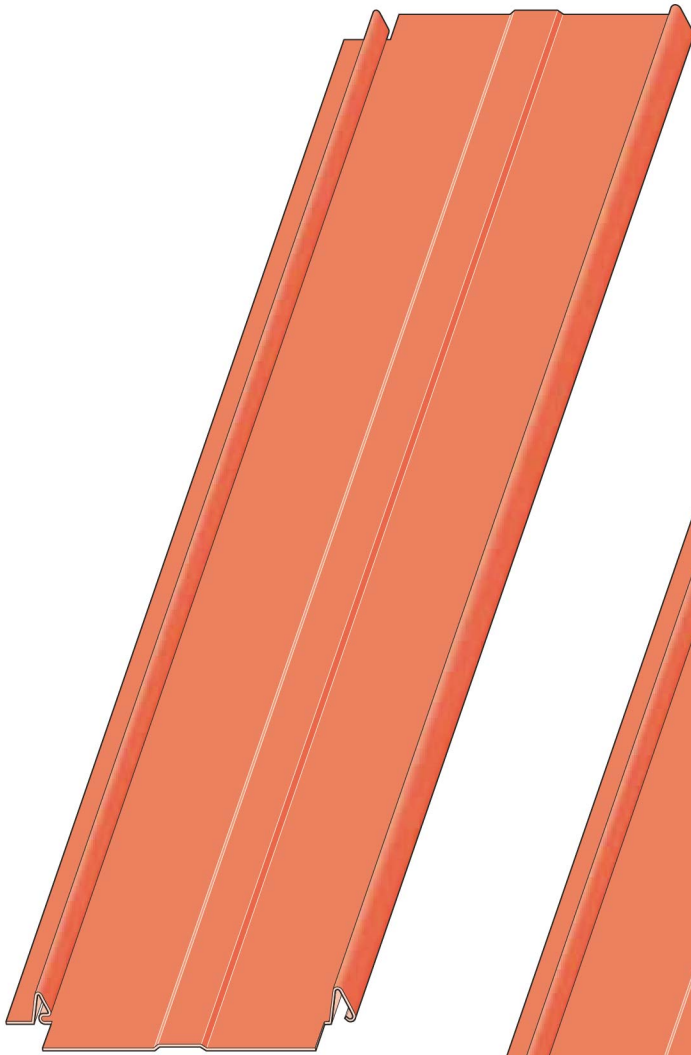
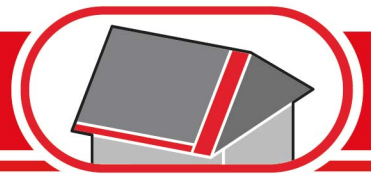

Panel ALEX

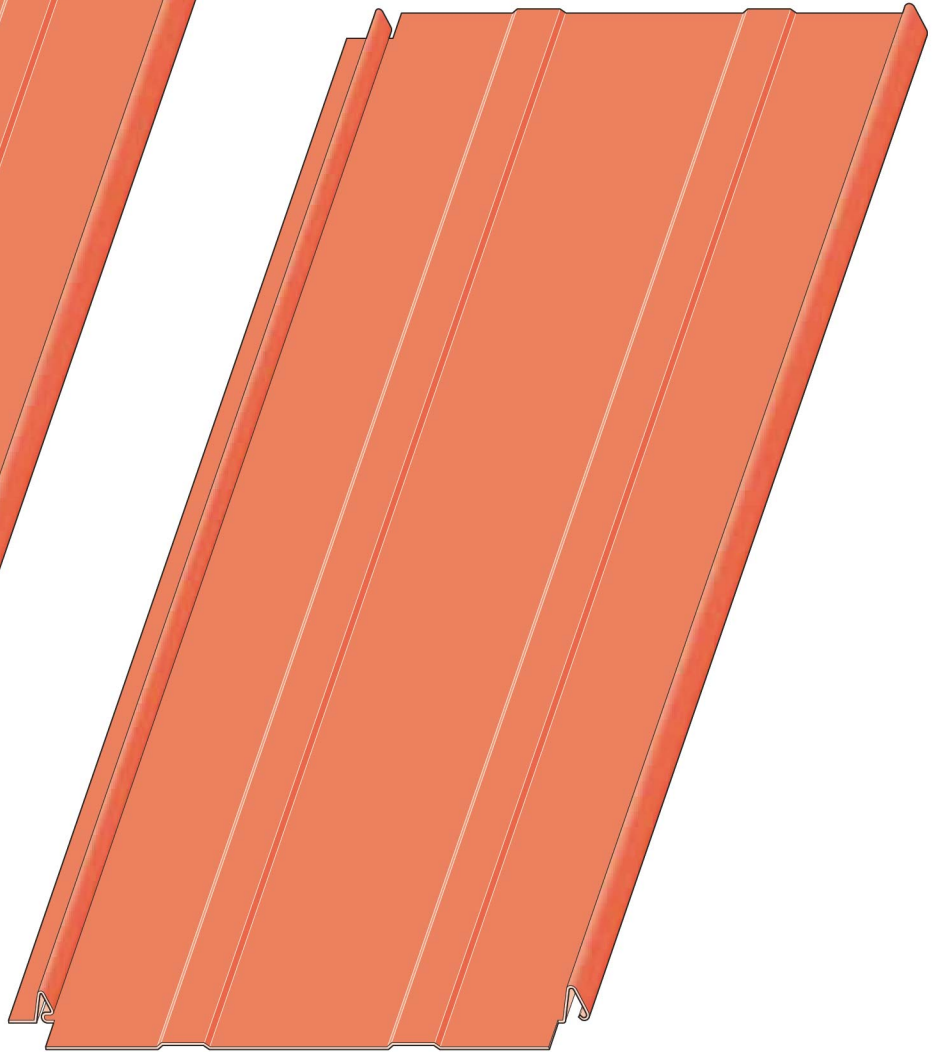

Panel OSKAR



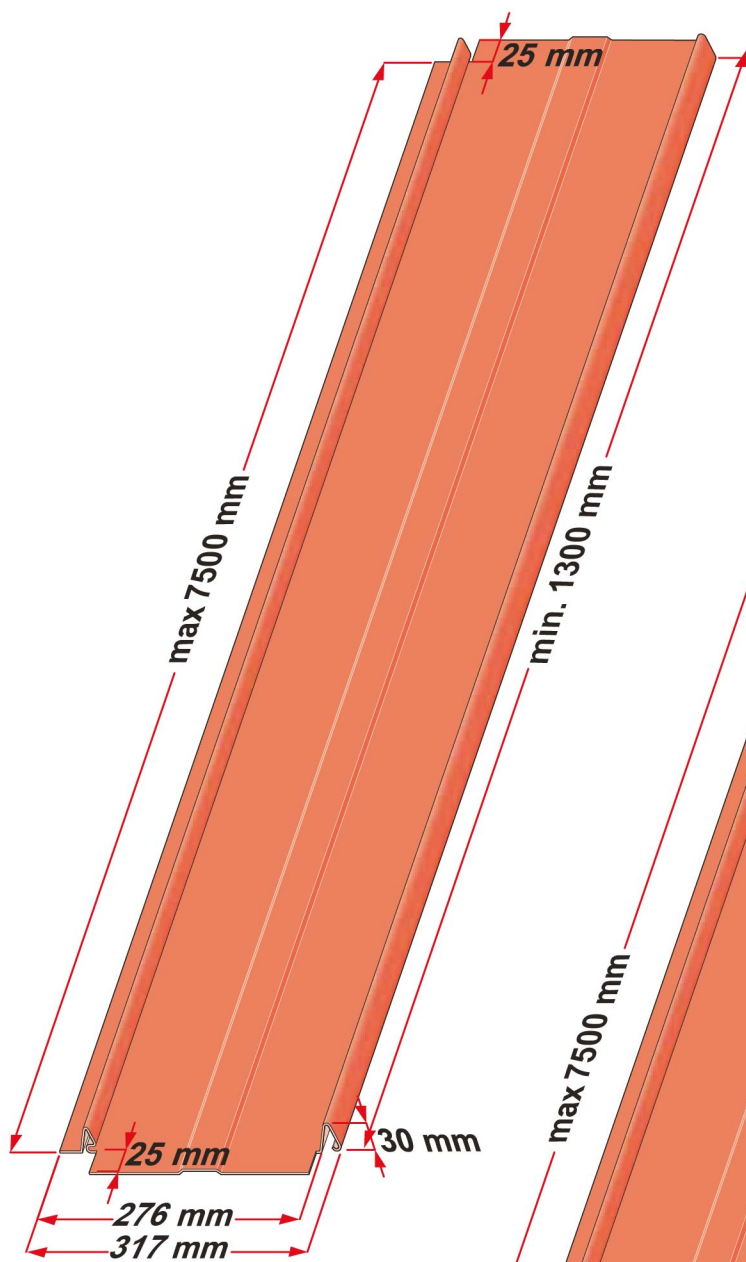
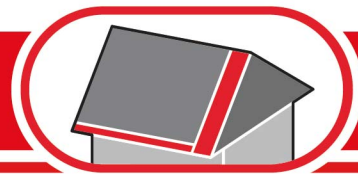

Panel ALEX

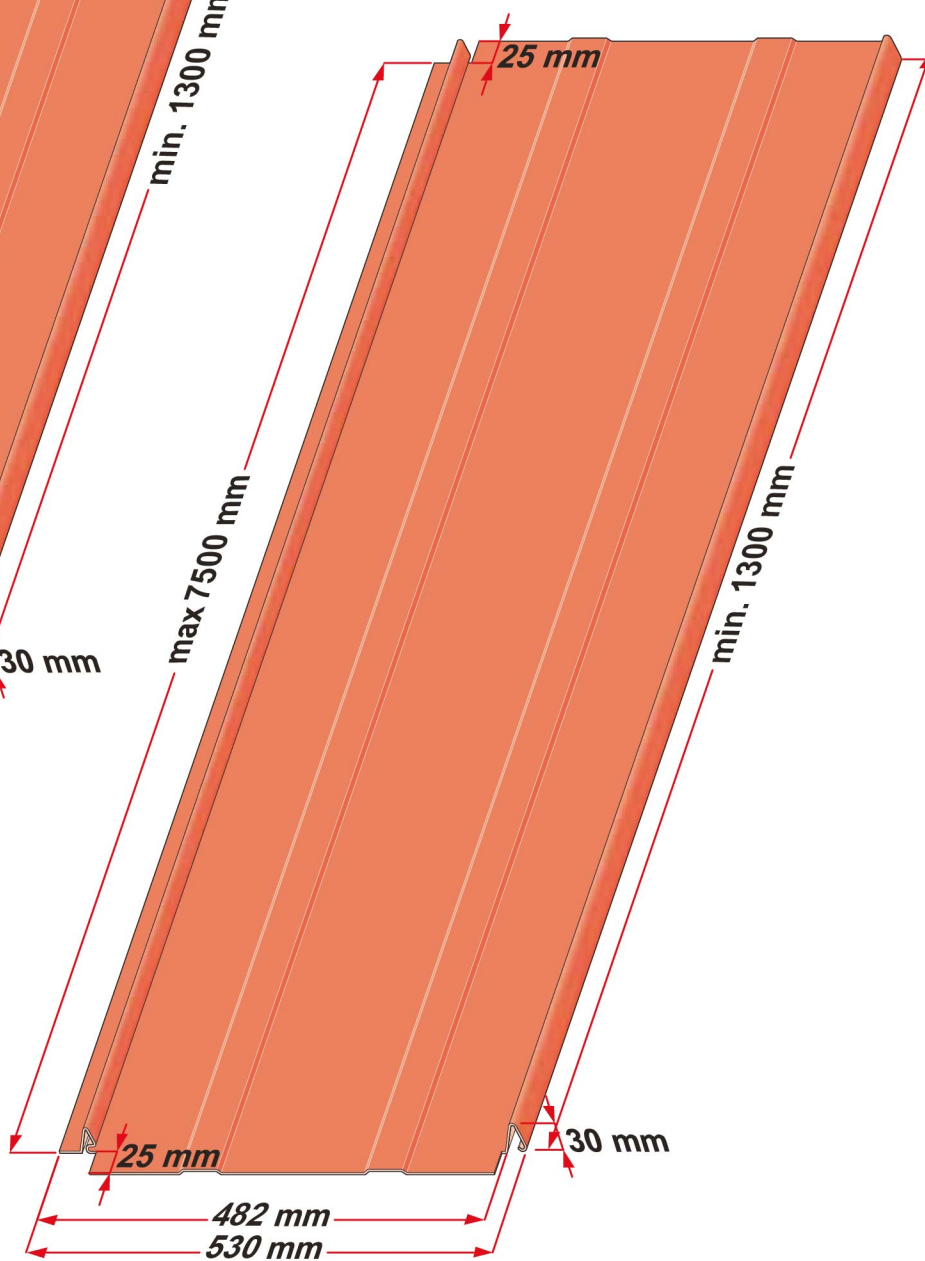

Panel OSKAR

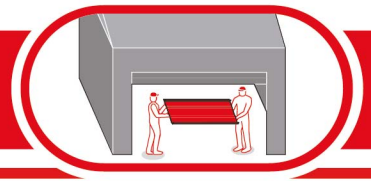

1

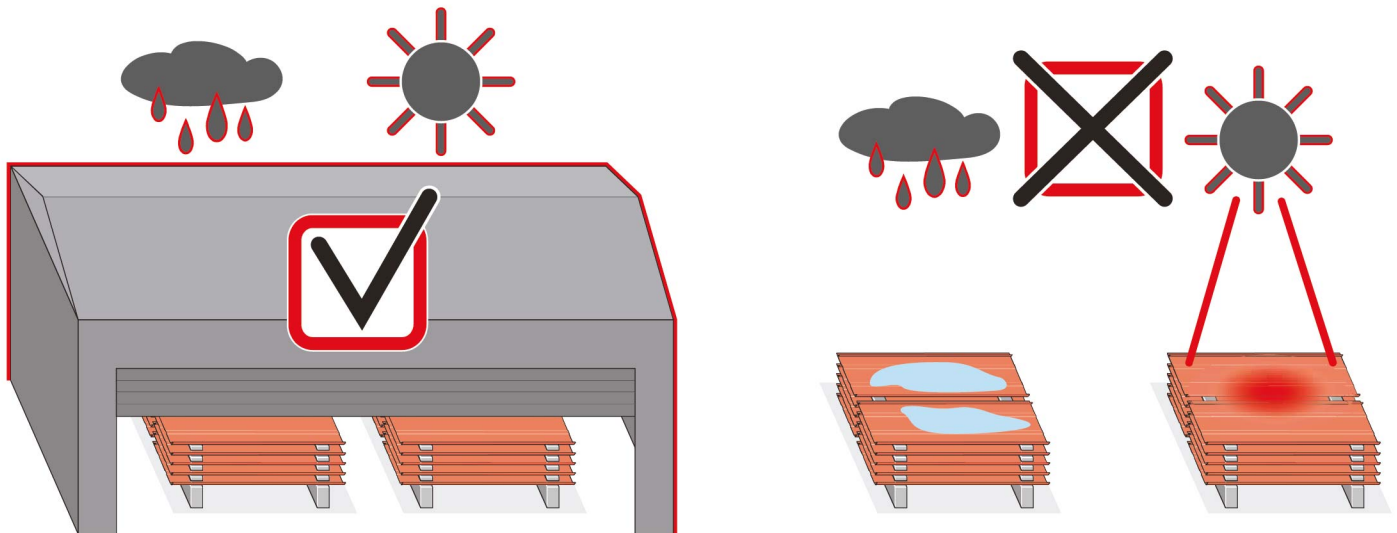
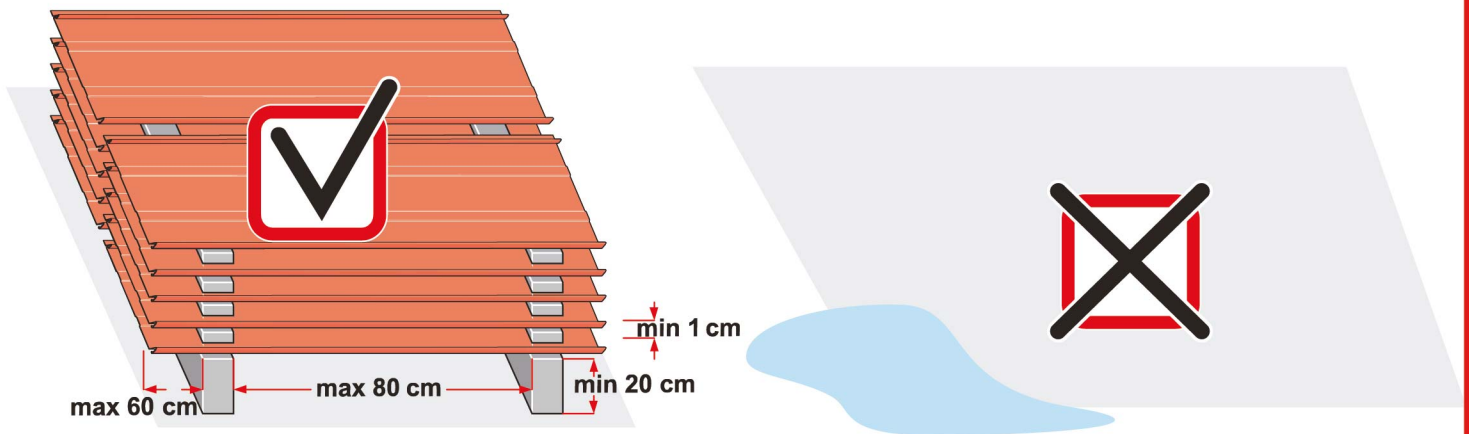
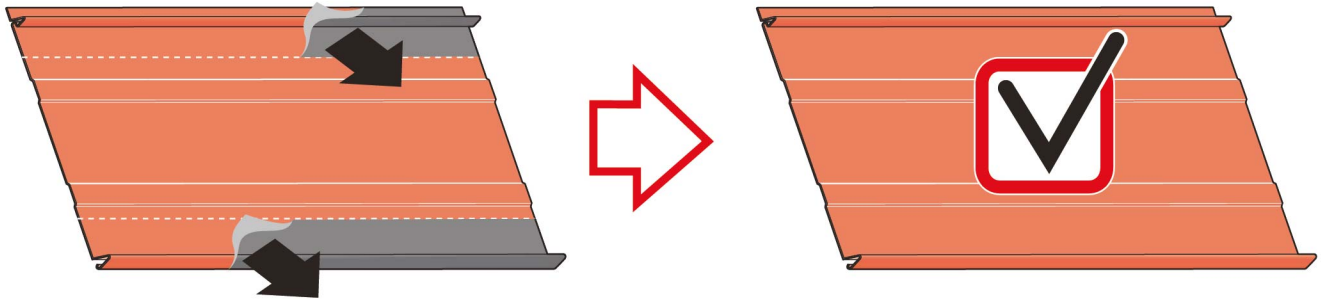

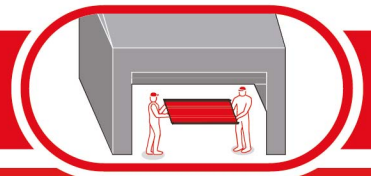

2

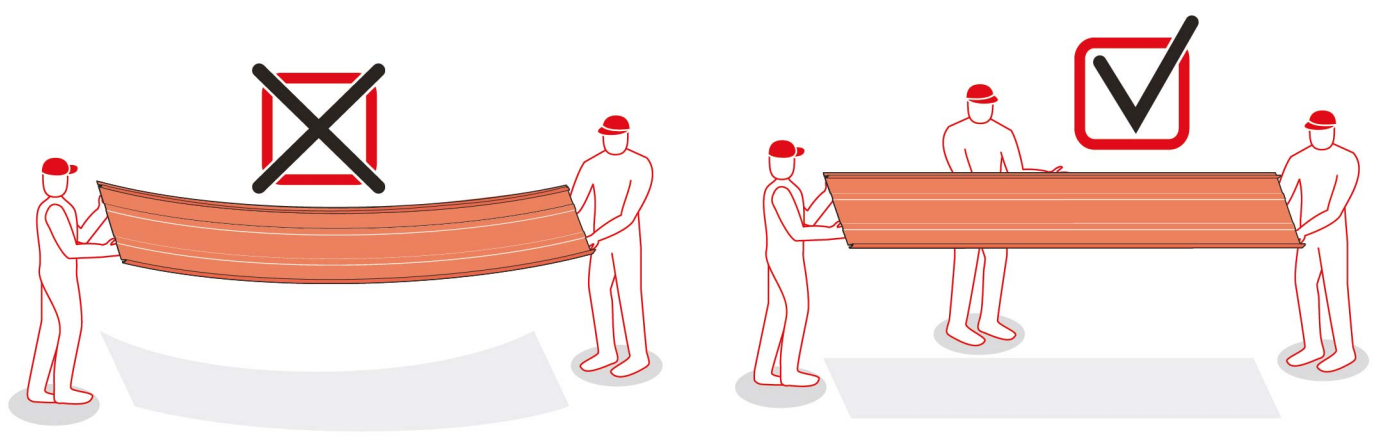
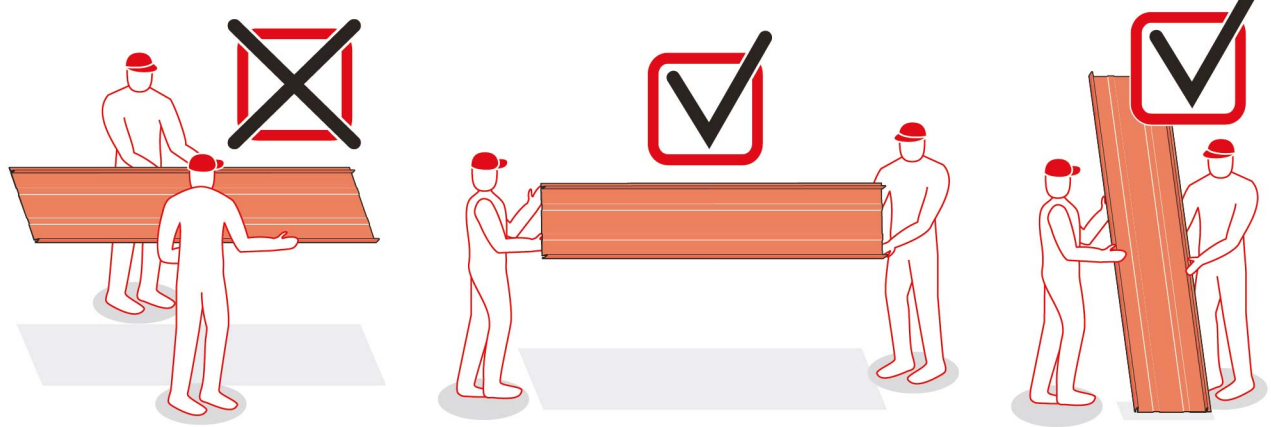
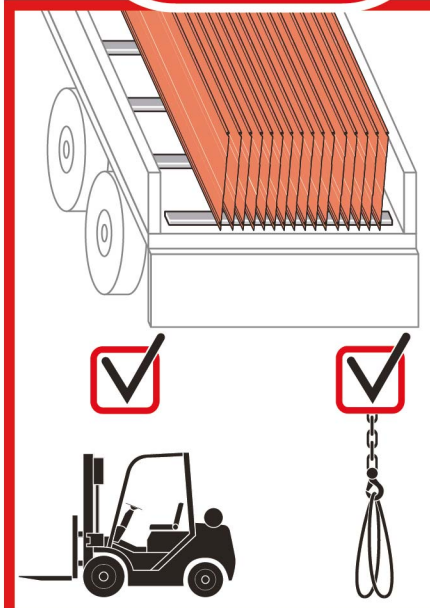
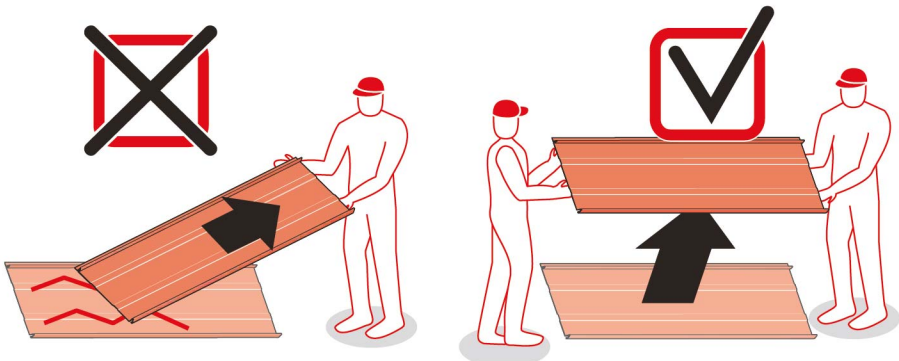

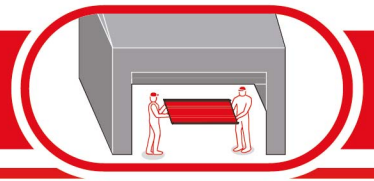

3

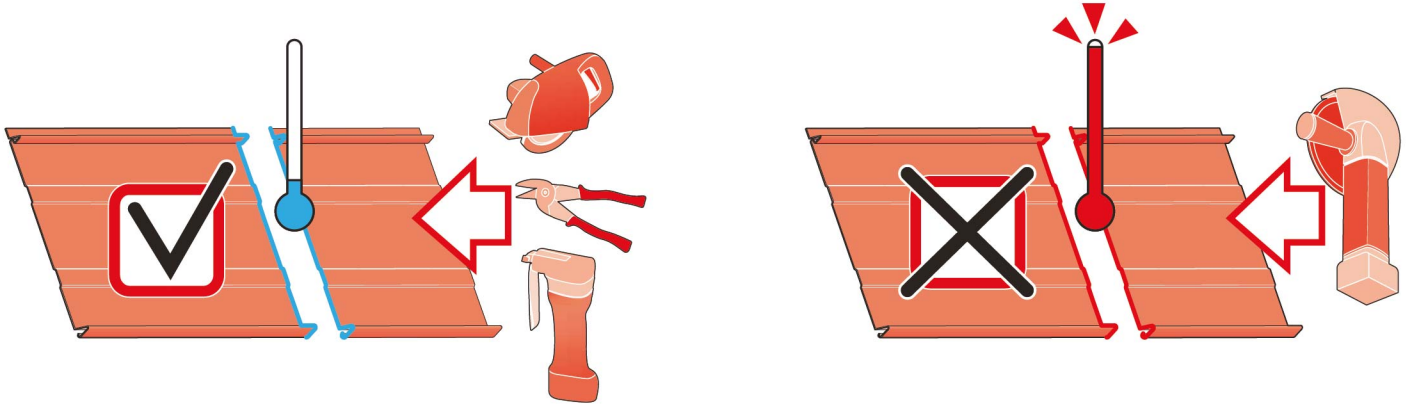

4

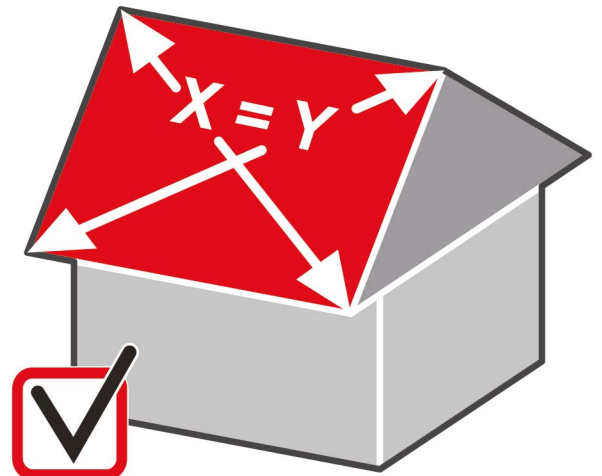
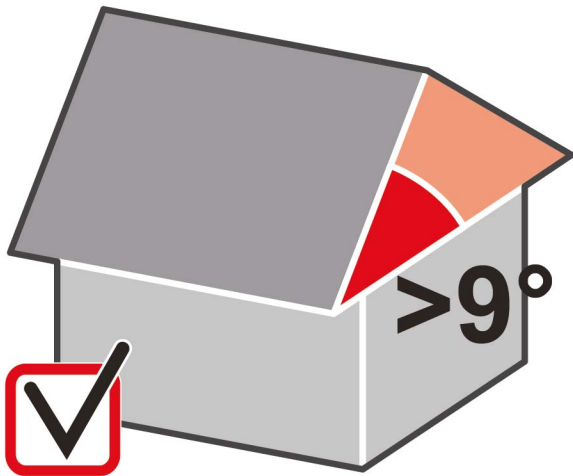

5

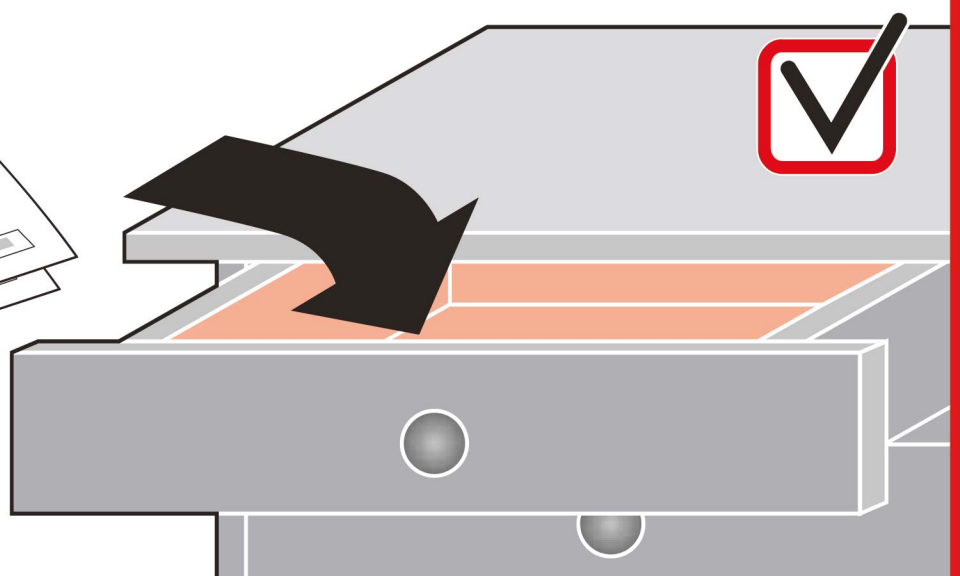
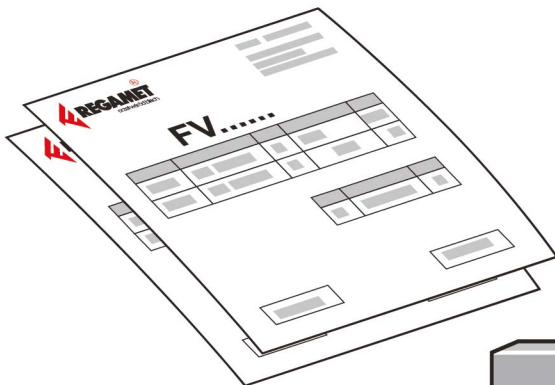

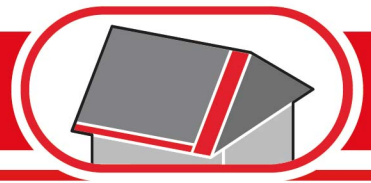

6

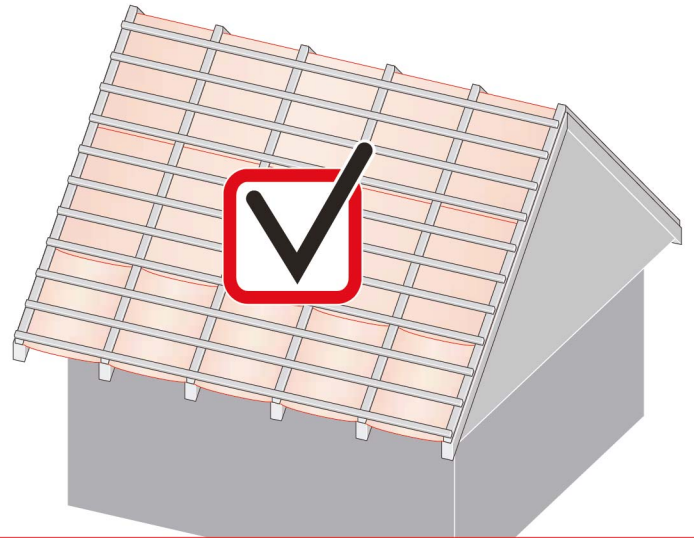
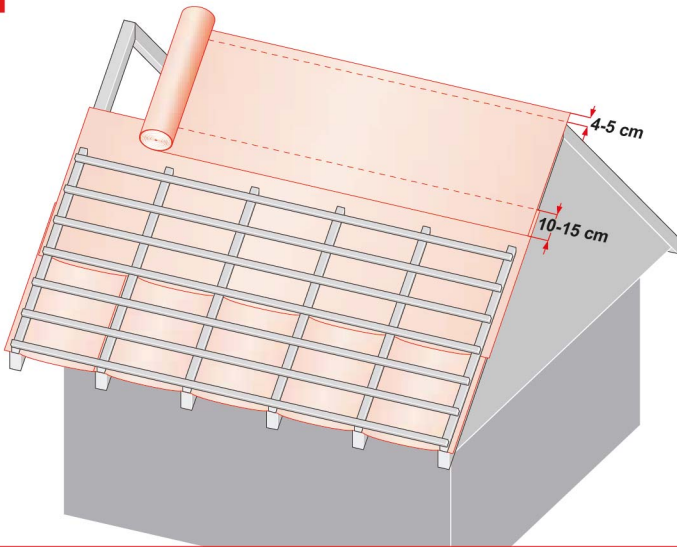

7

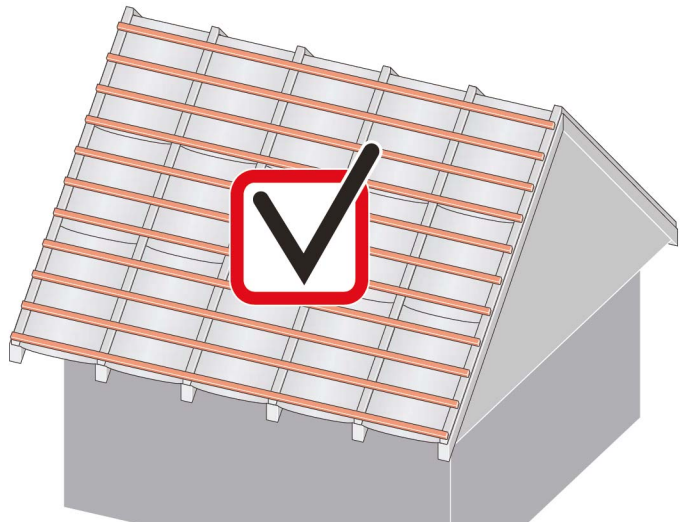
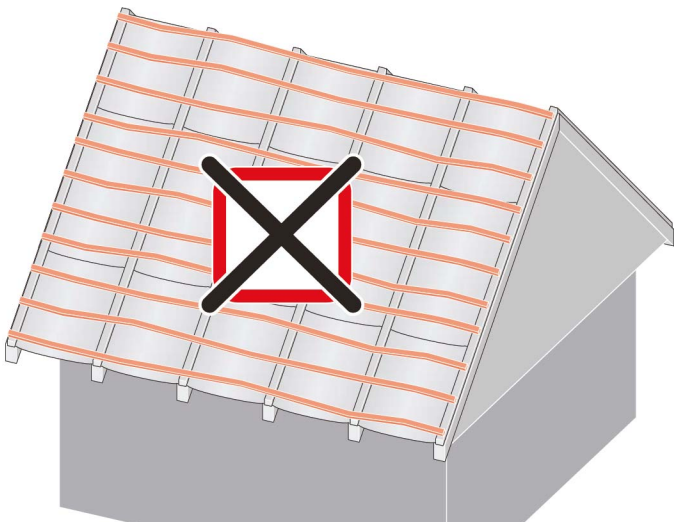
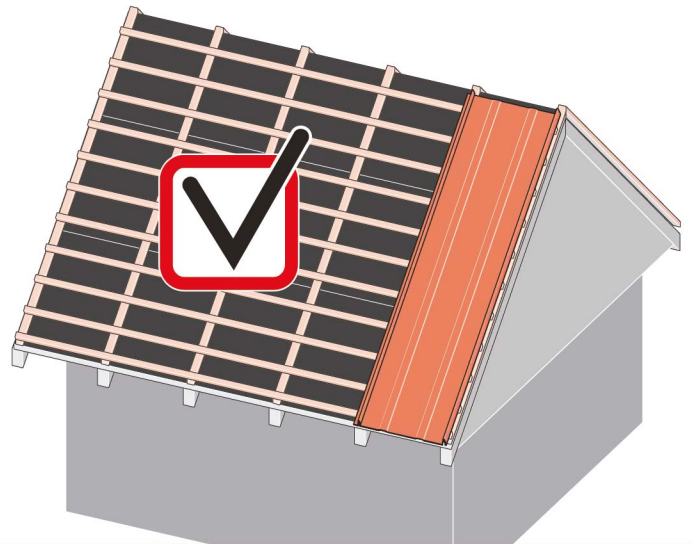
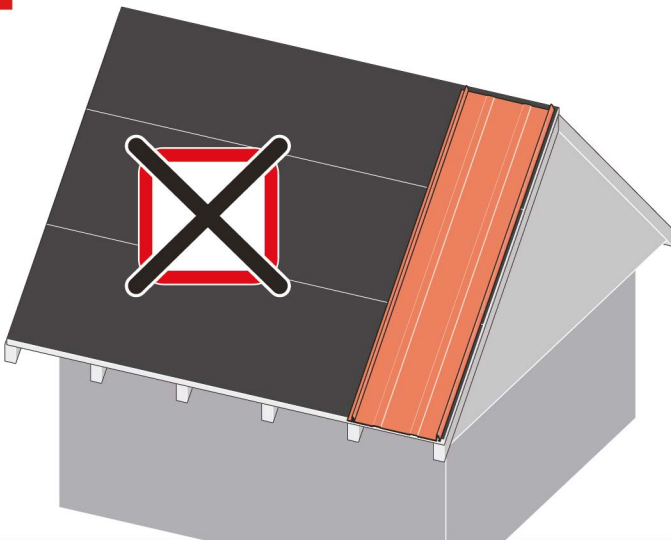

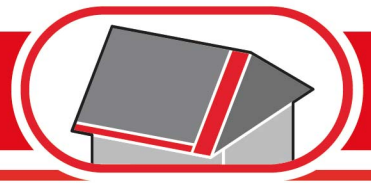

8a nachylenie połaci dachu powyżej 40 stopni
łaty max 35 cm, zalecane 25 cm

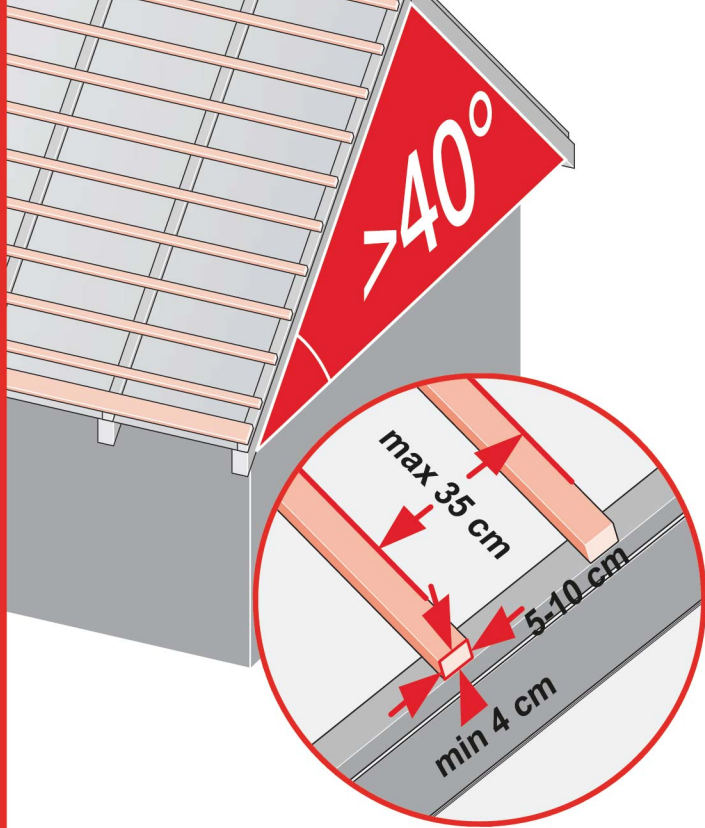

8b nachylenie połaci dachu powyżej 20 stopni
deskowanie ażurowe (deska co 10 cm)

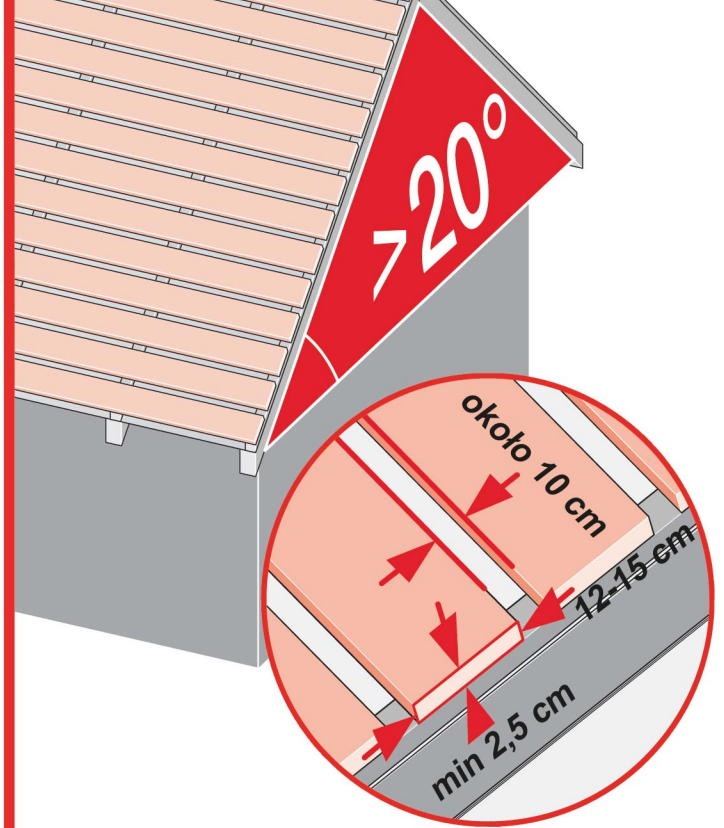

8c nachylenie połaci dachu poniżej 20 stopni
deskowanie pełne

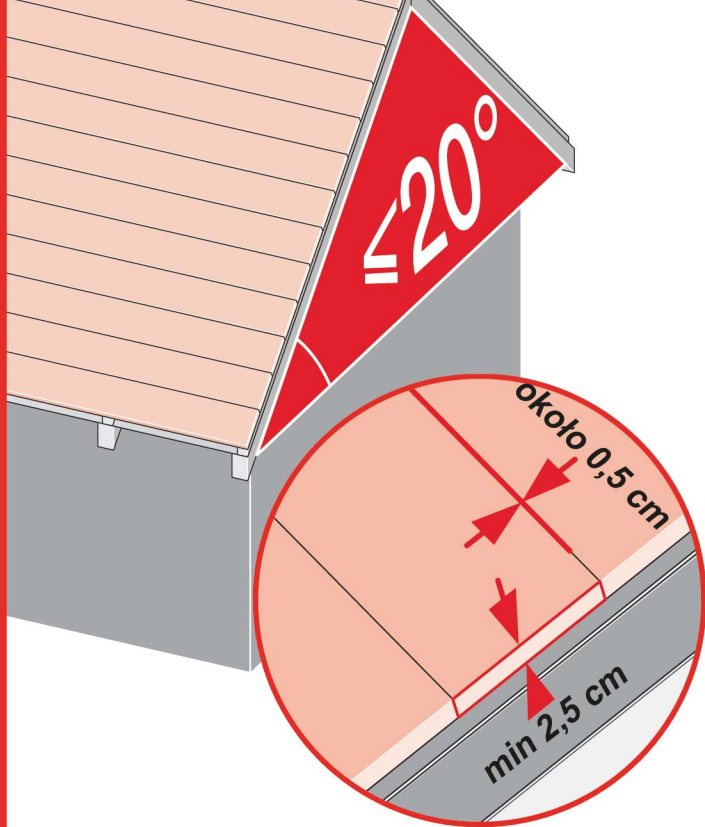

8d nachylenie połaci dachu poniżej 20 stopni
plyta OSB

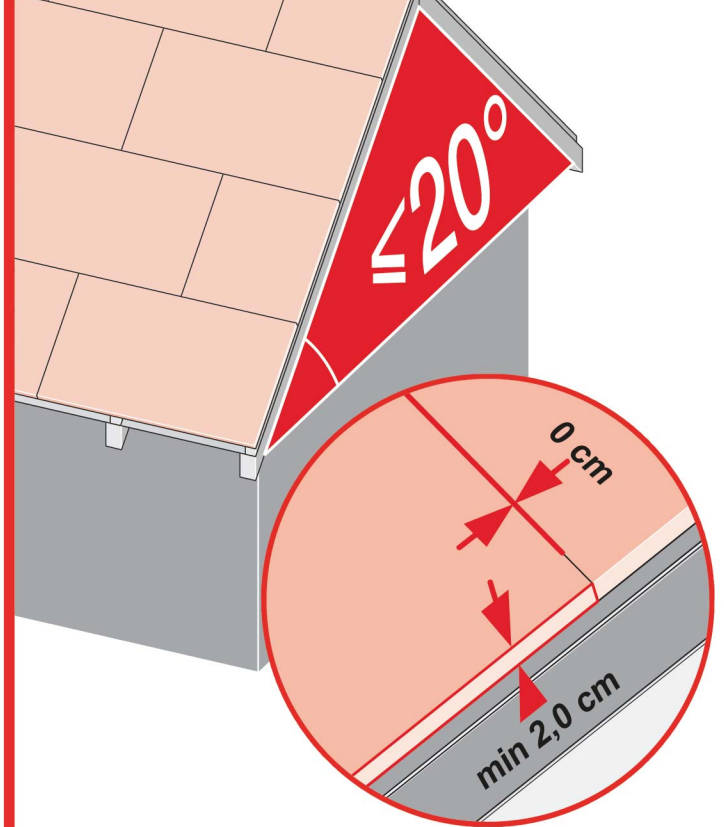

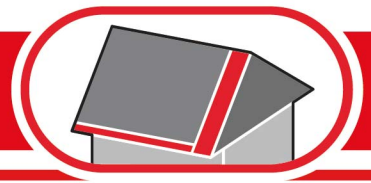

9a

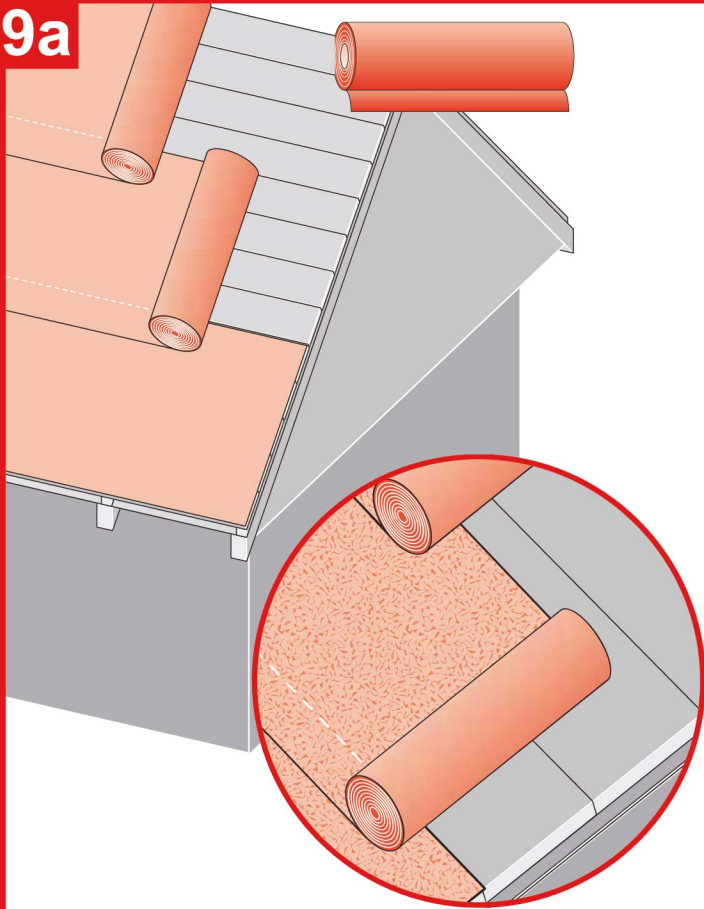

9b

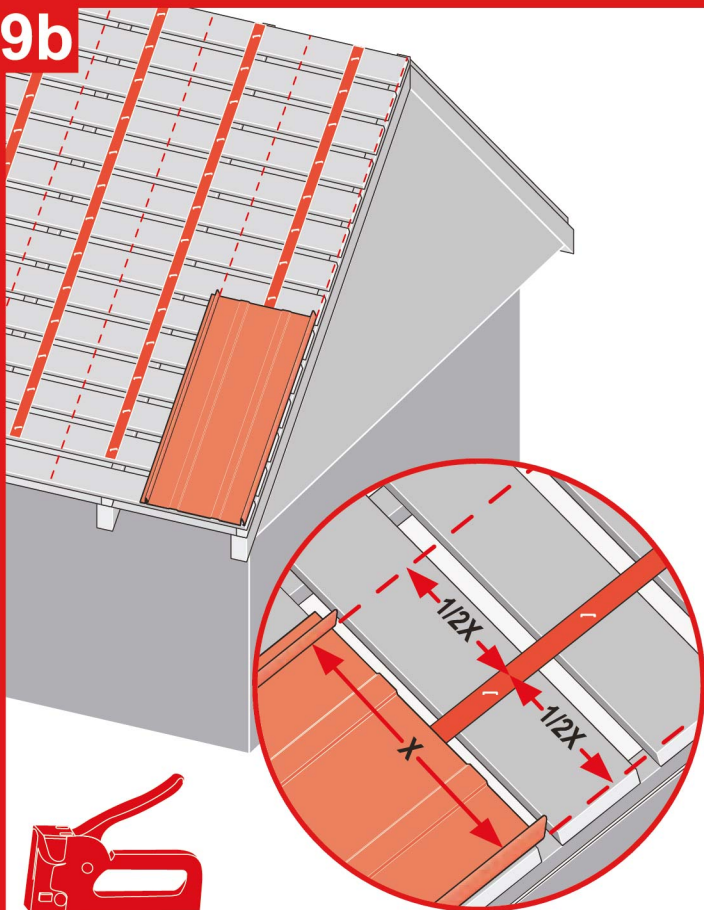

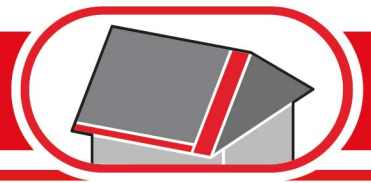

10

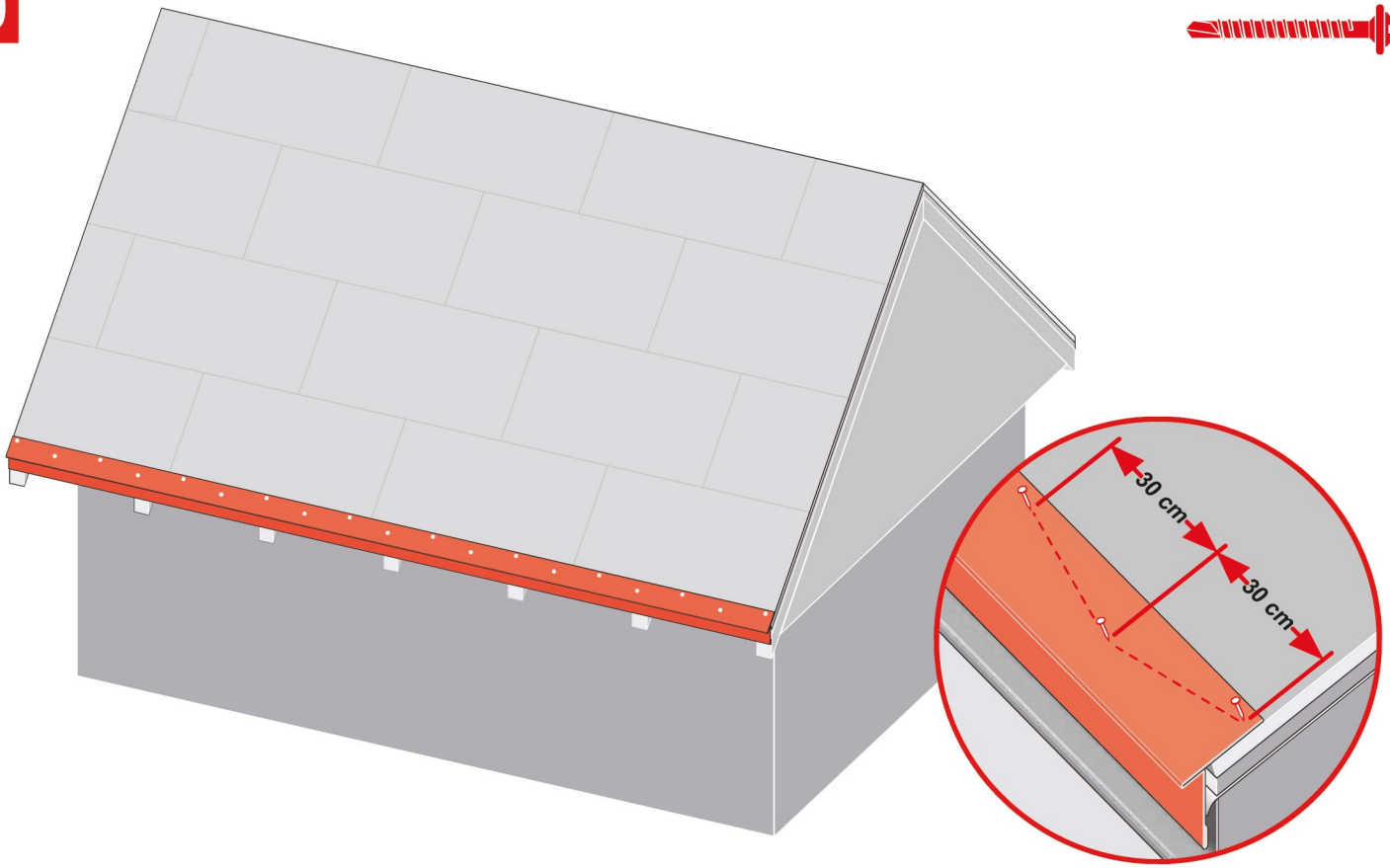

11



A=B=.....cm

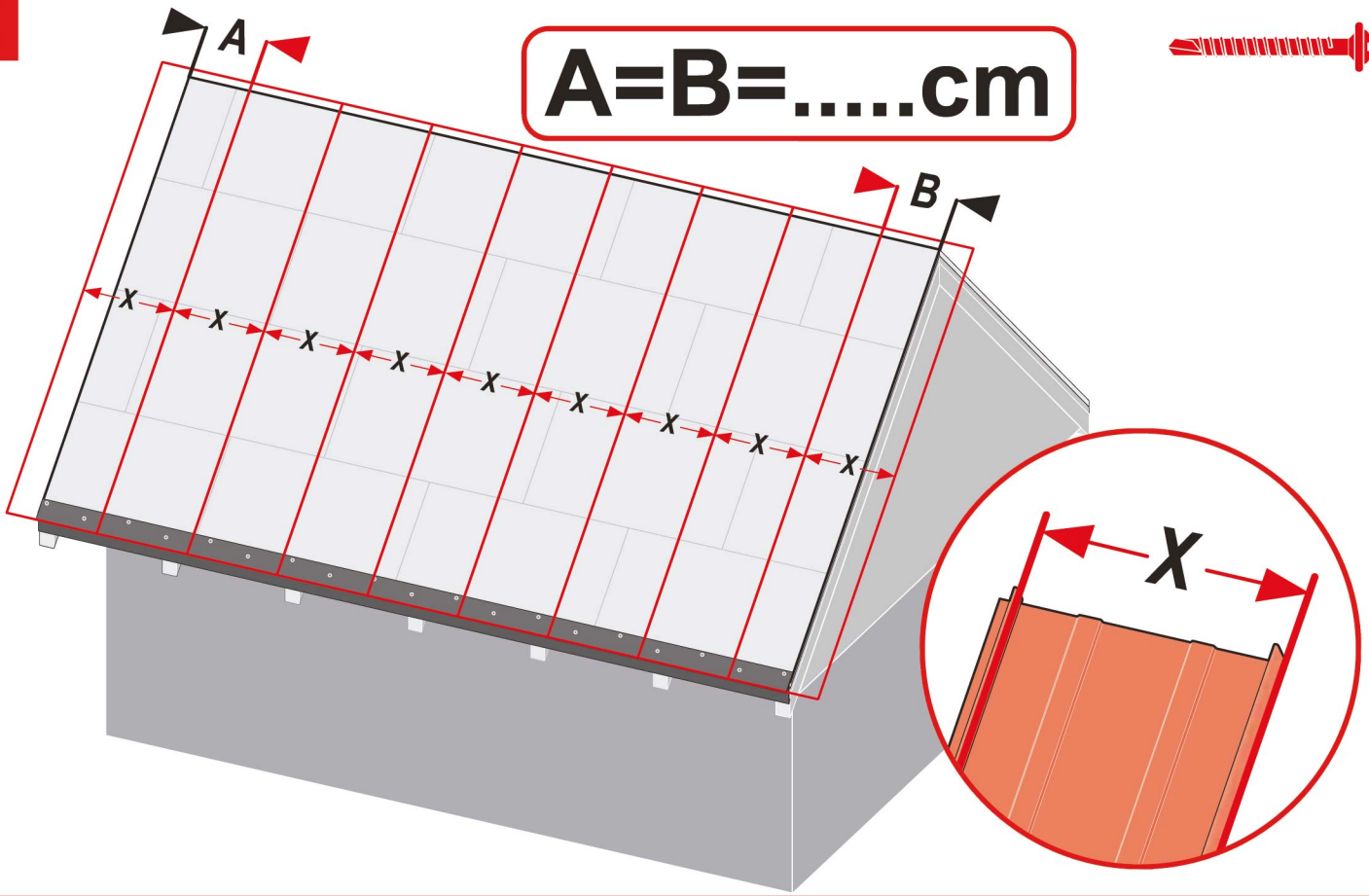

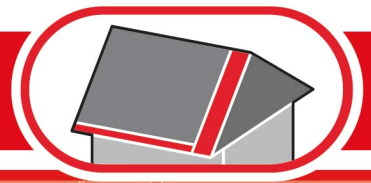

12

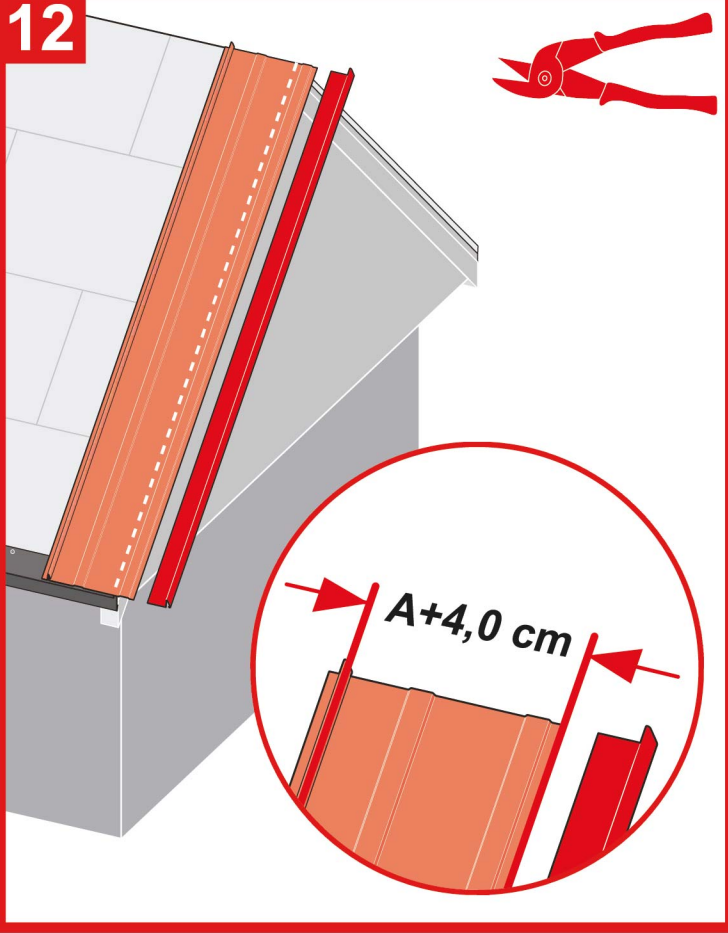

a

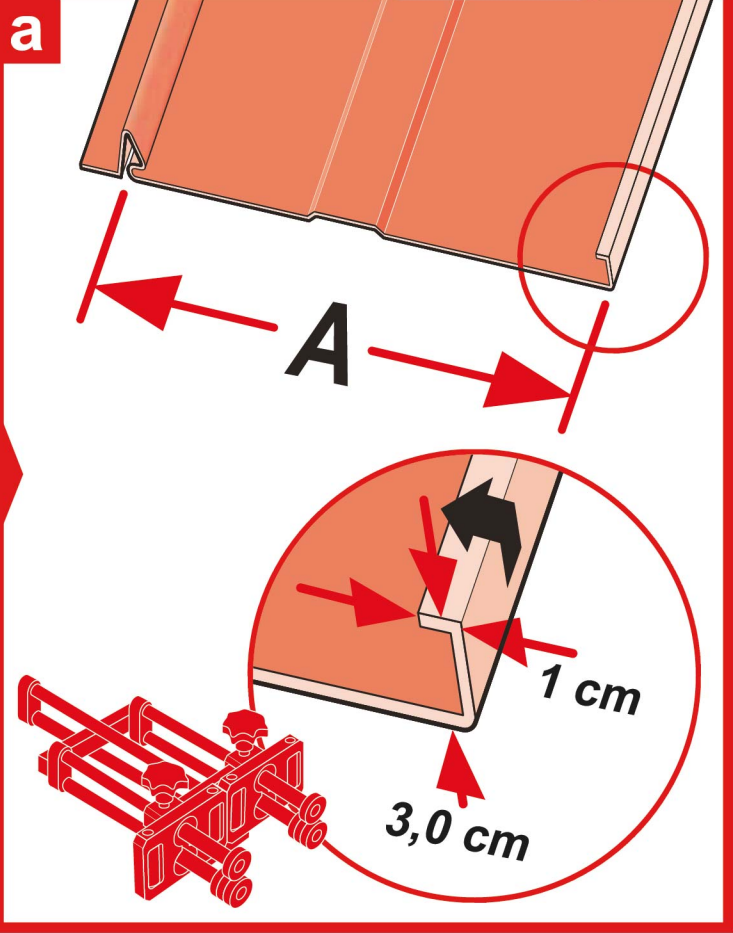

b

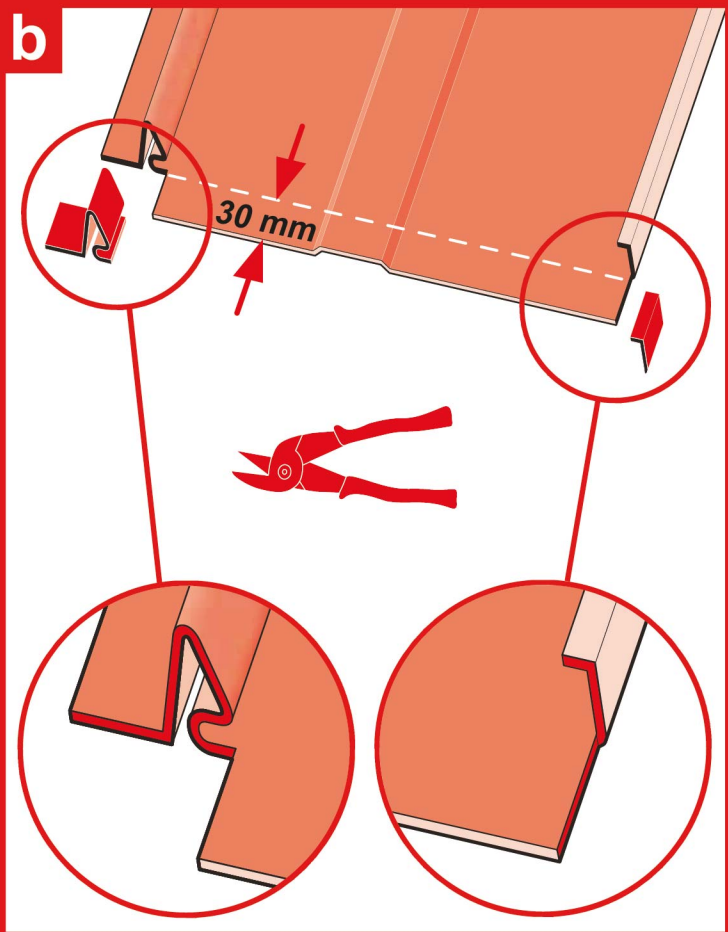

c

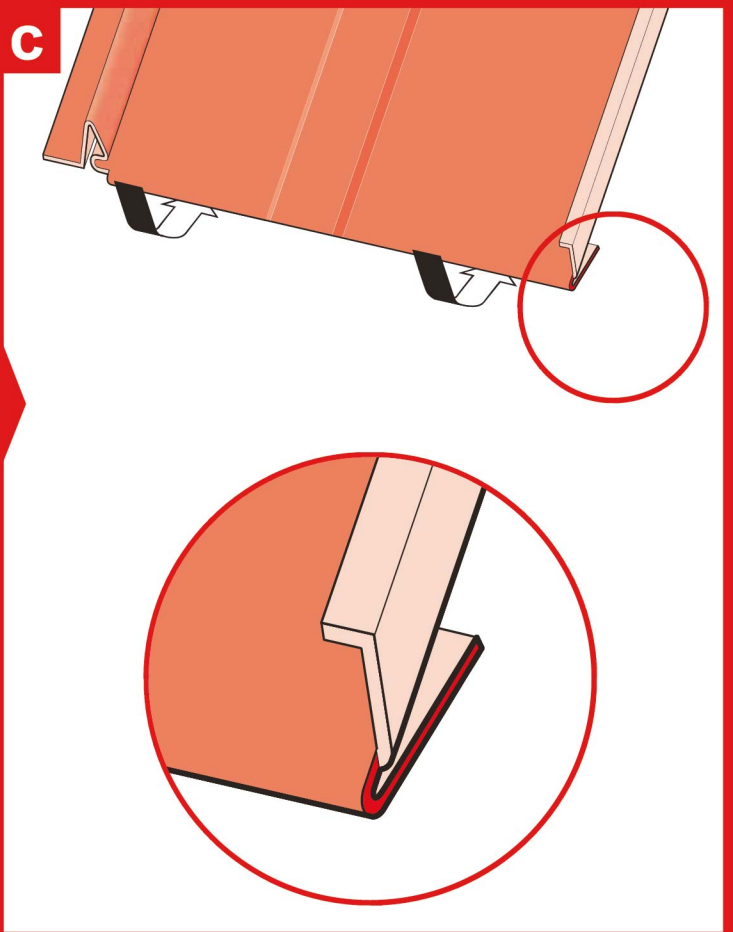

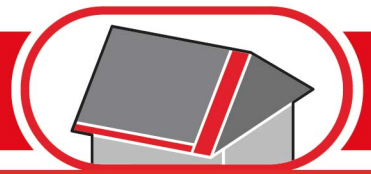

13

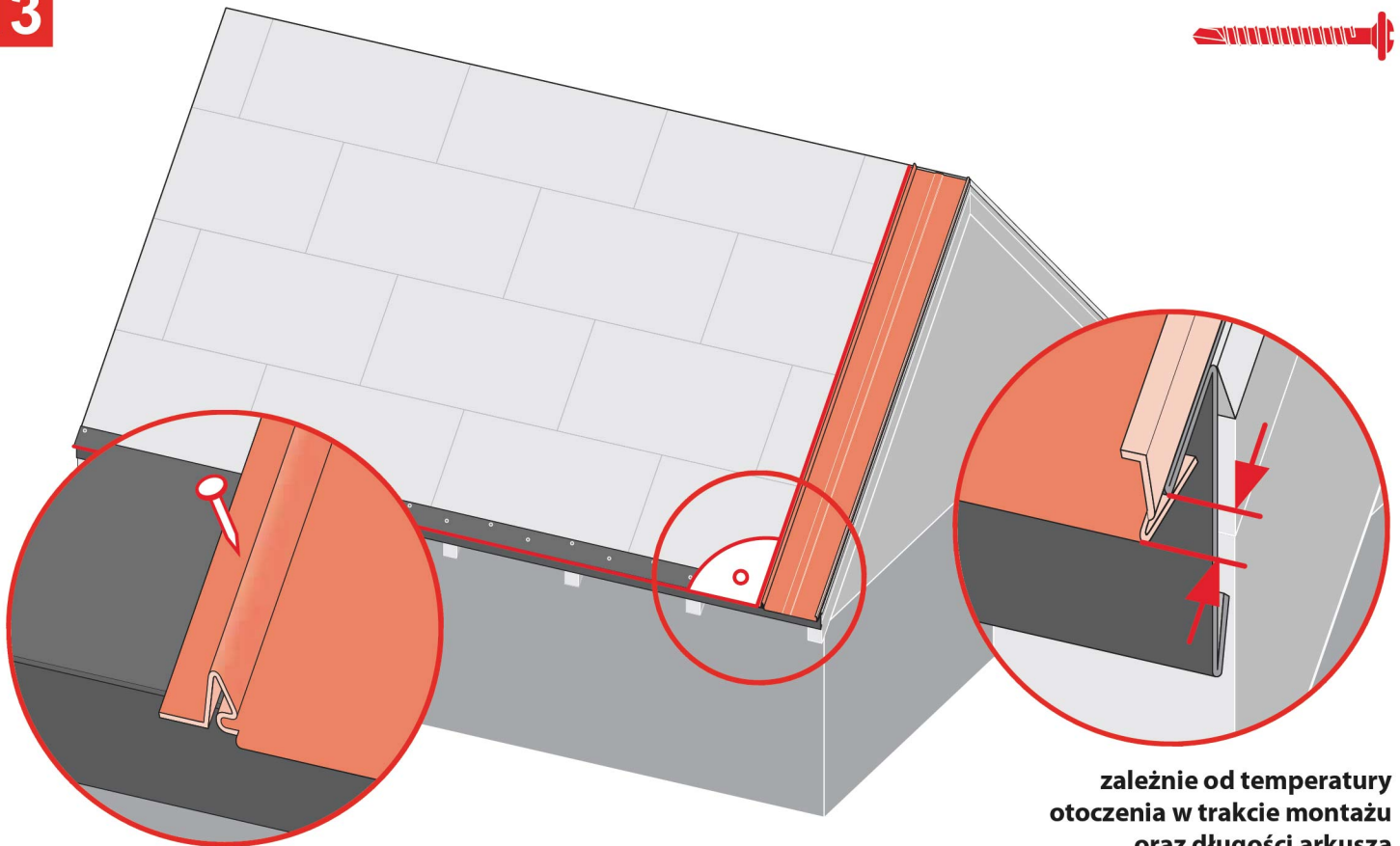

zależnie od temperatury
otoczenia w trakcie montażu
oraz długości arkusza

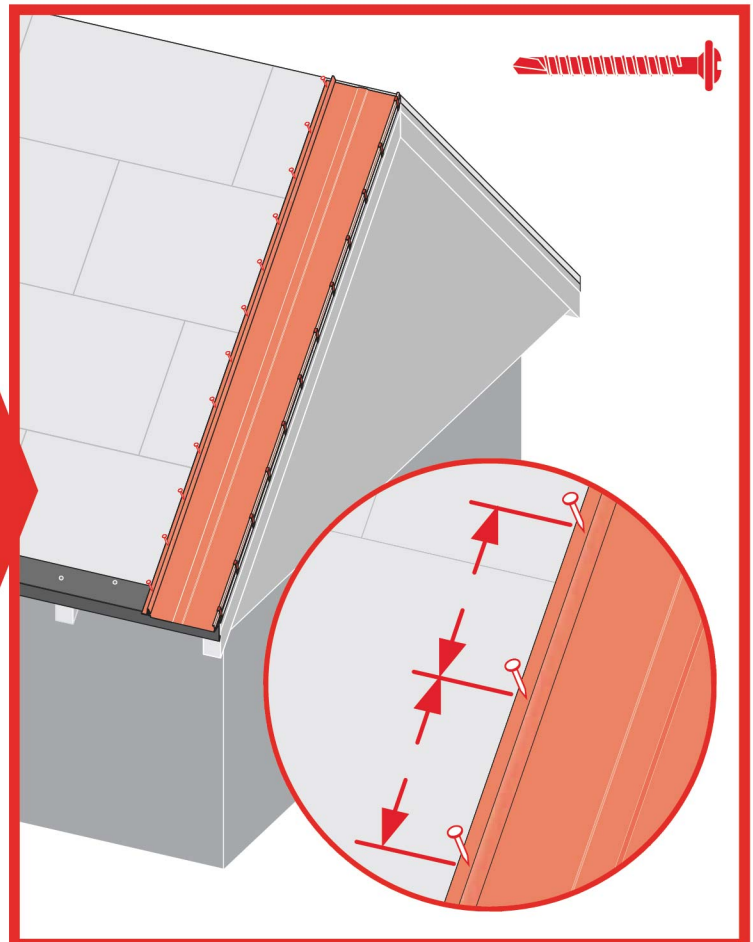
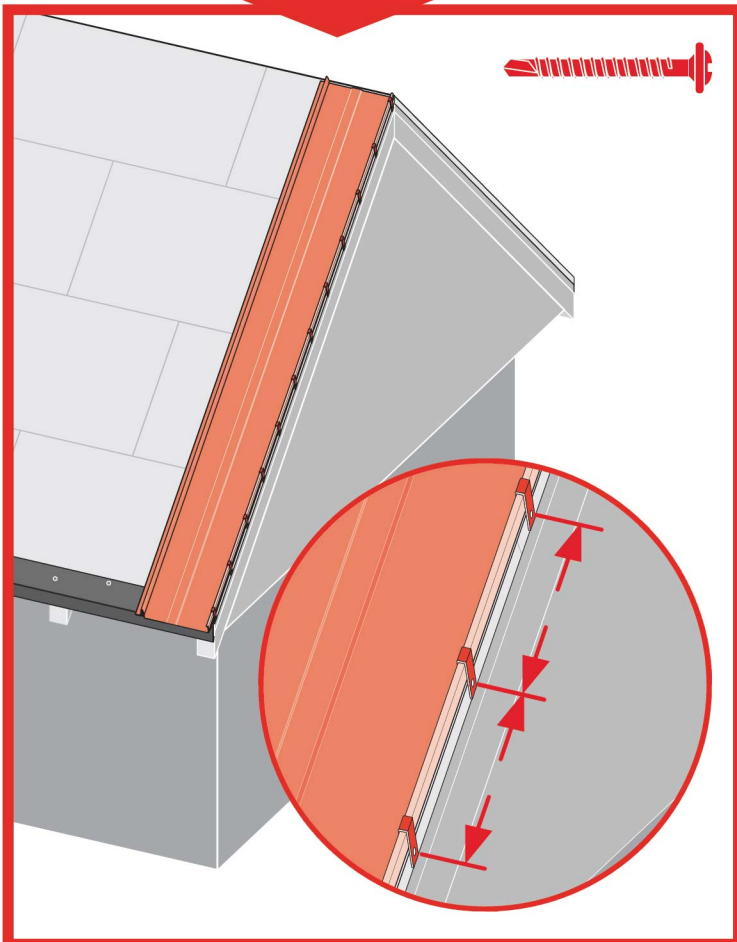

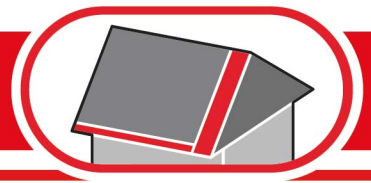

13a

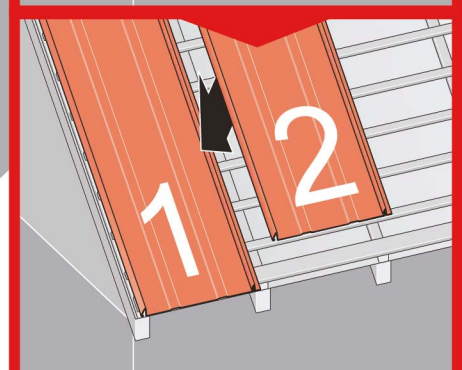
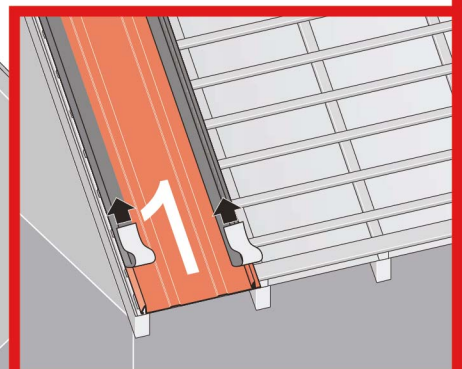
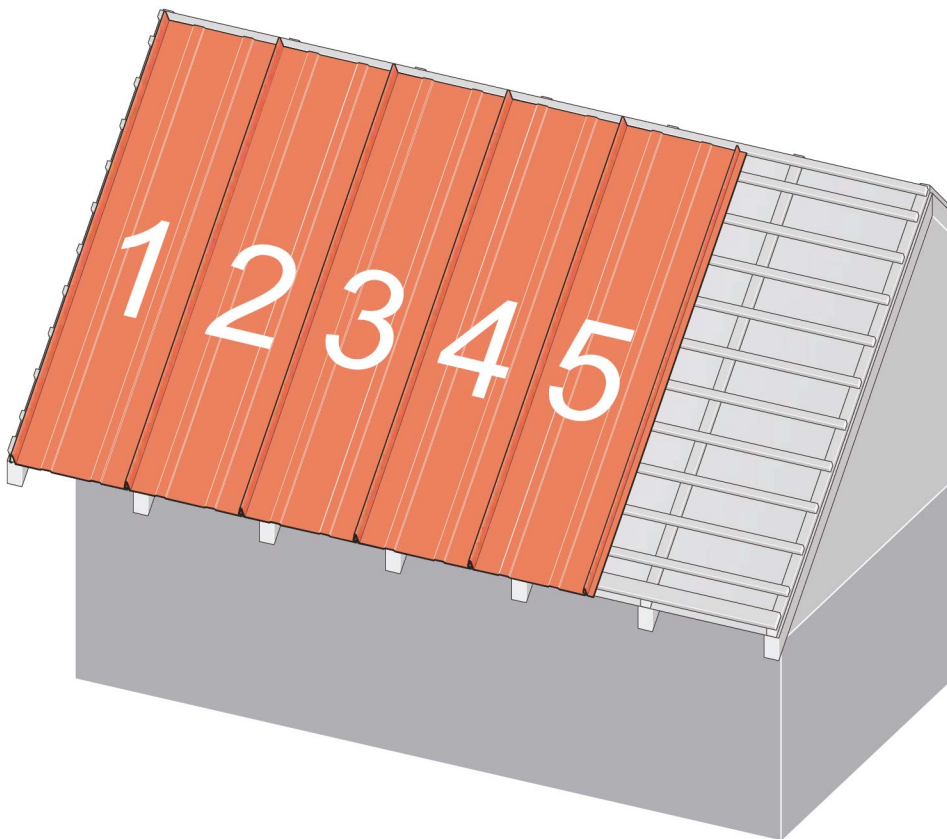
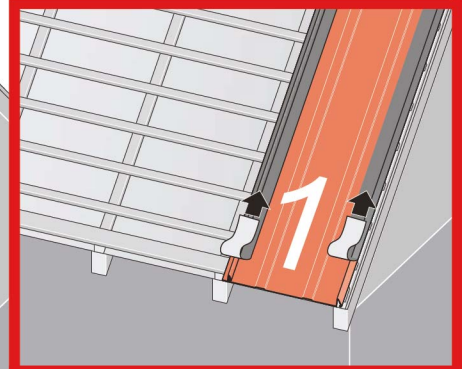
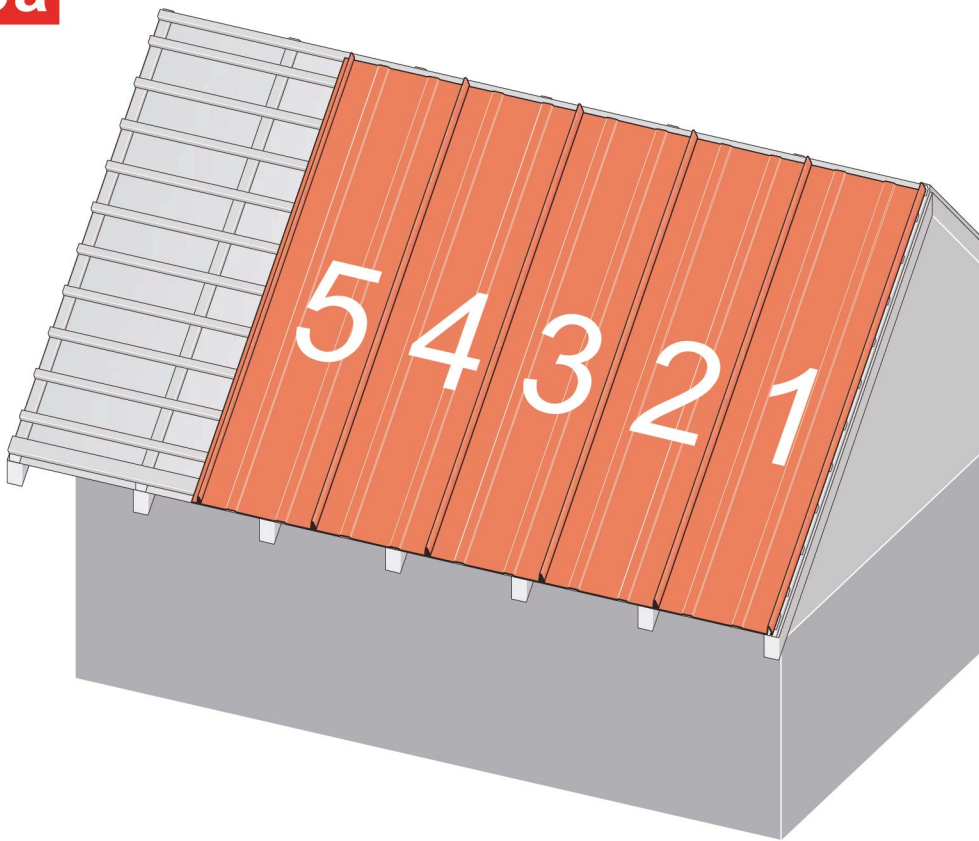

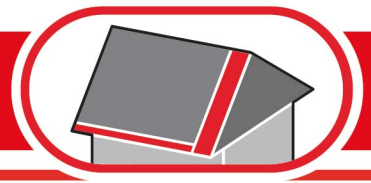

14

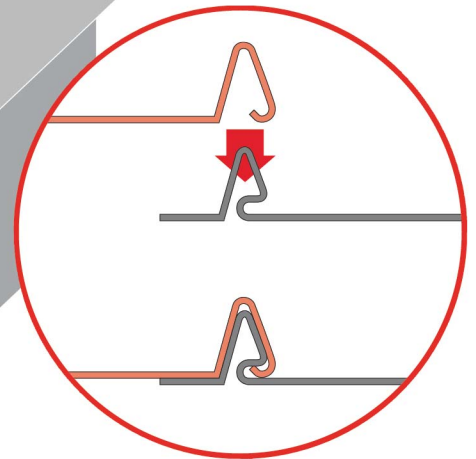
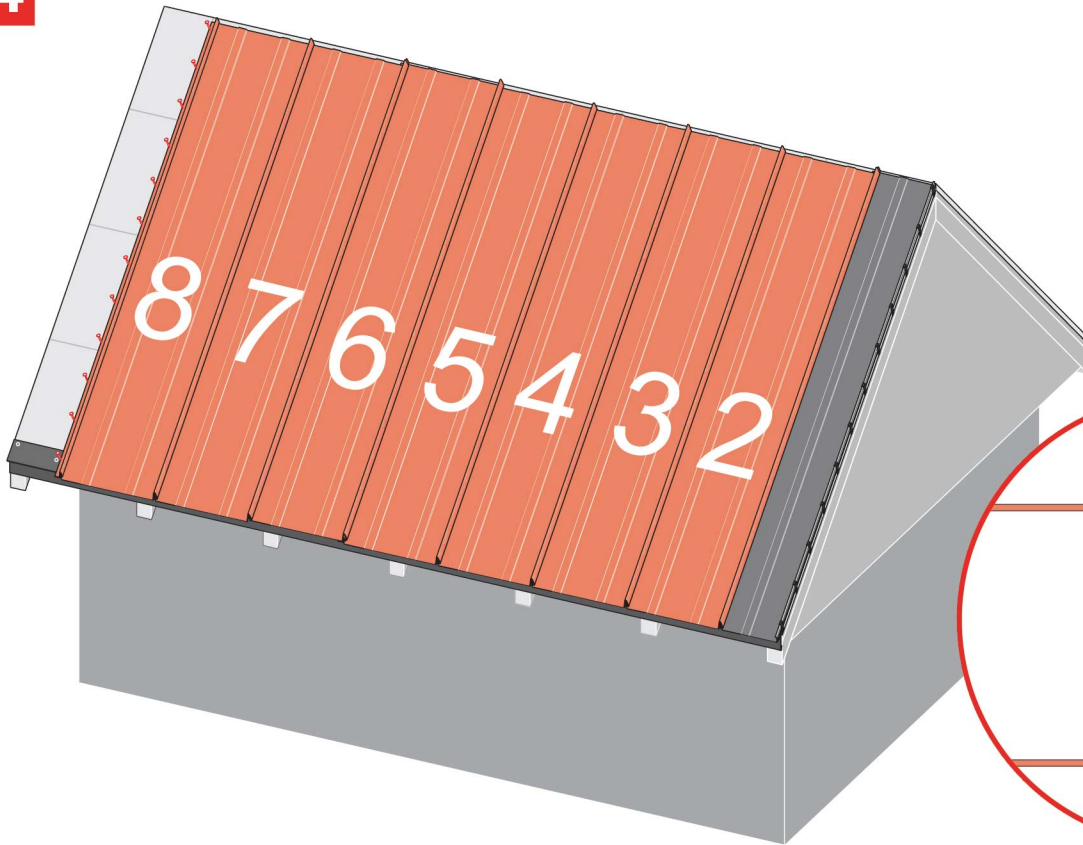

15

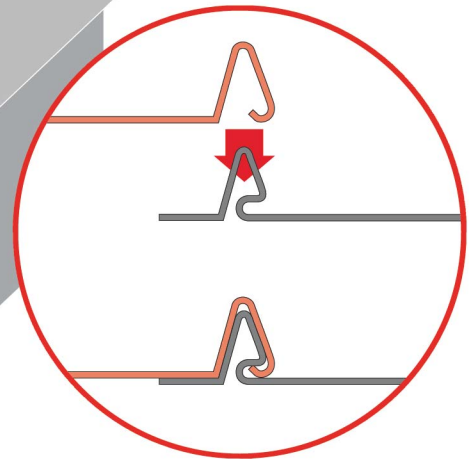
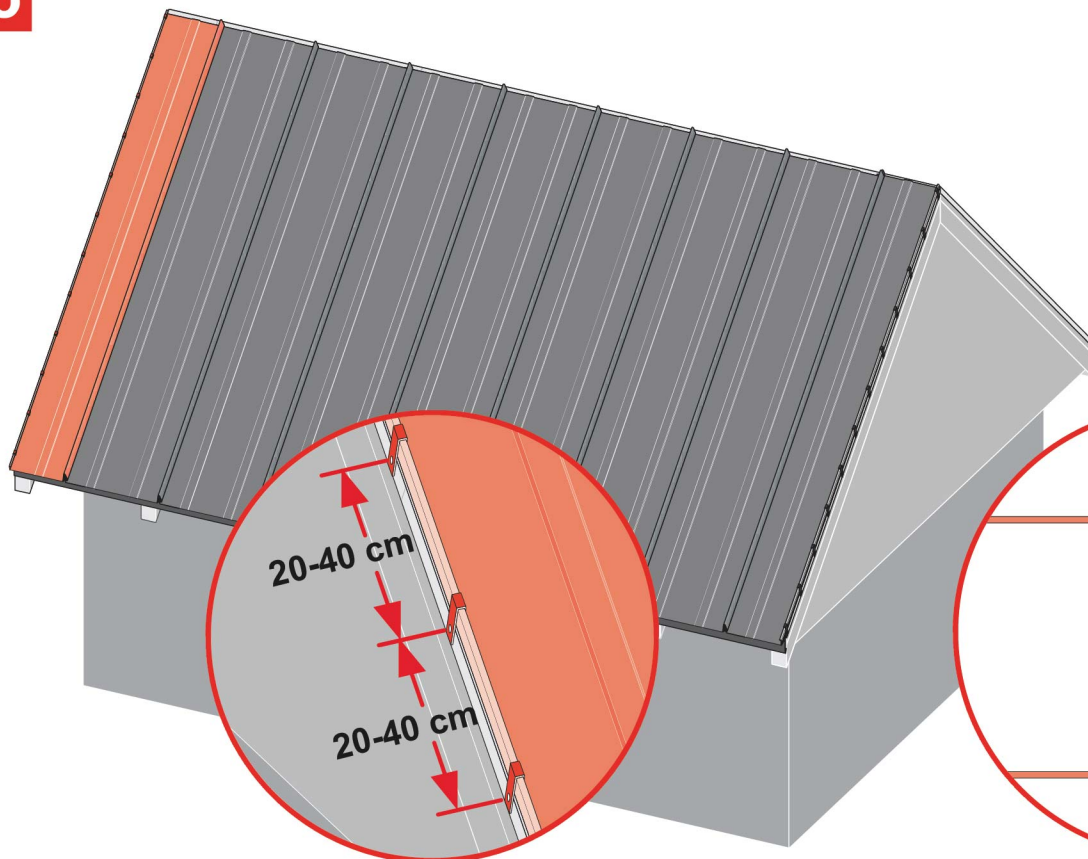

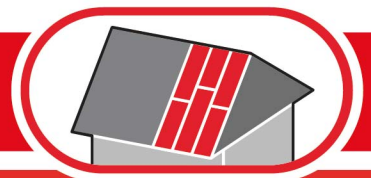

16

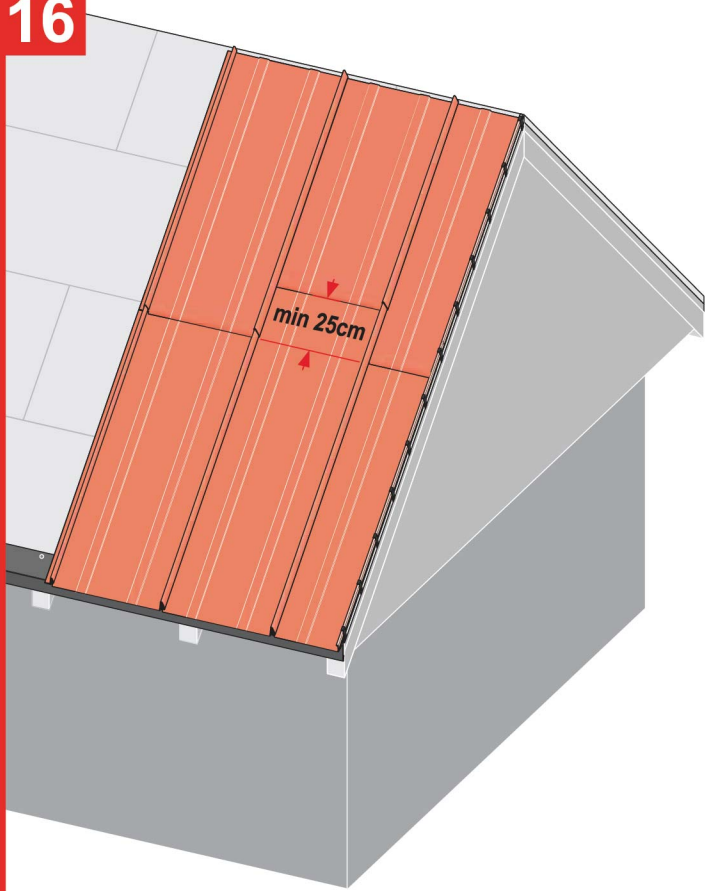

a

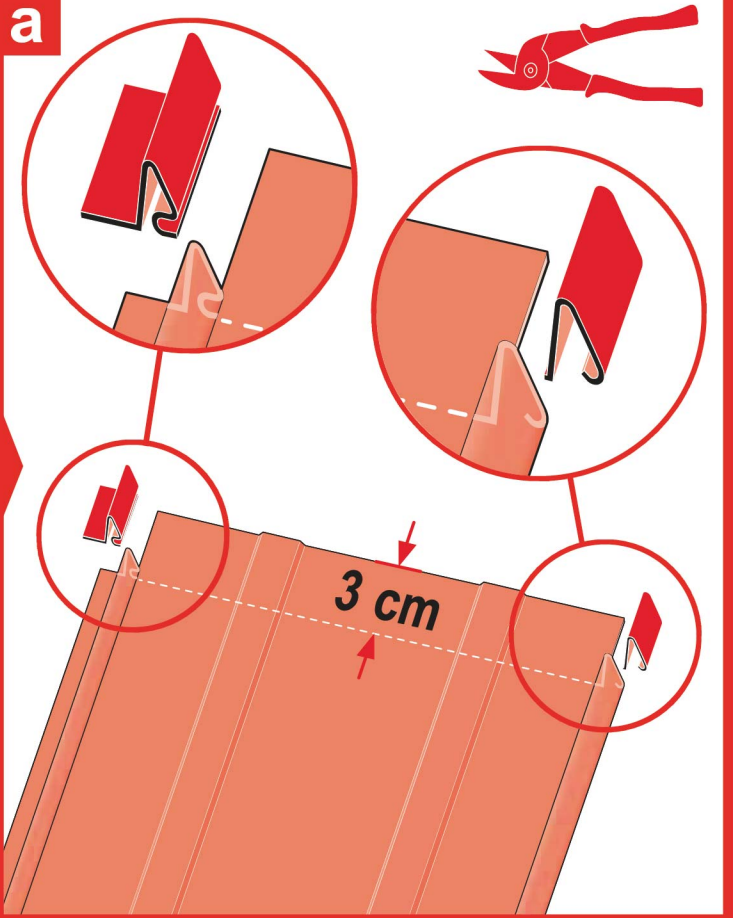

b

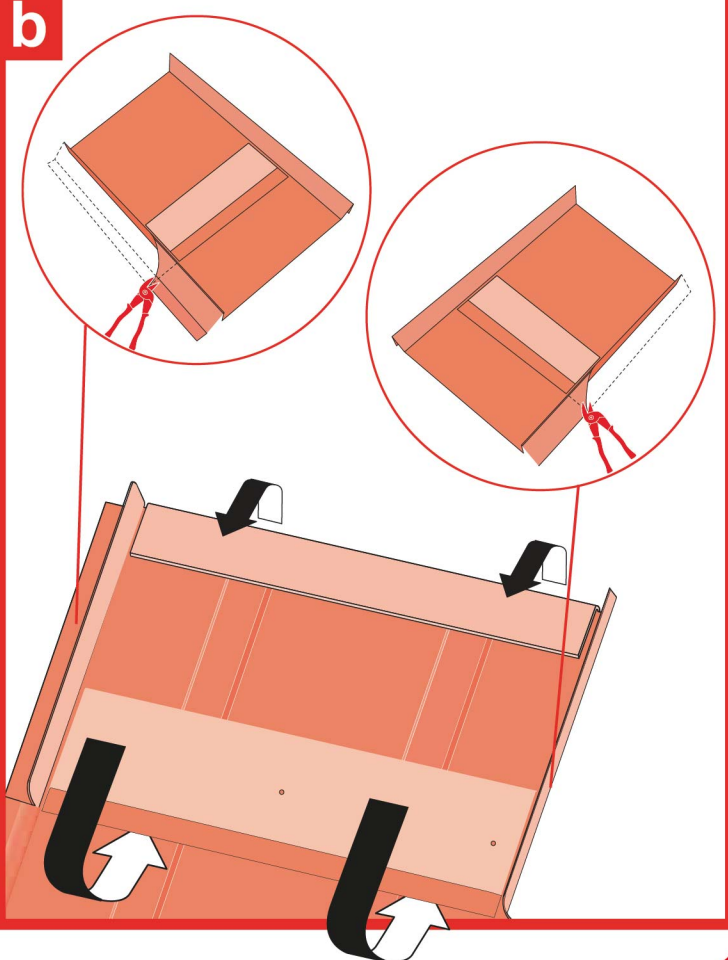

c

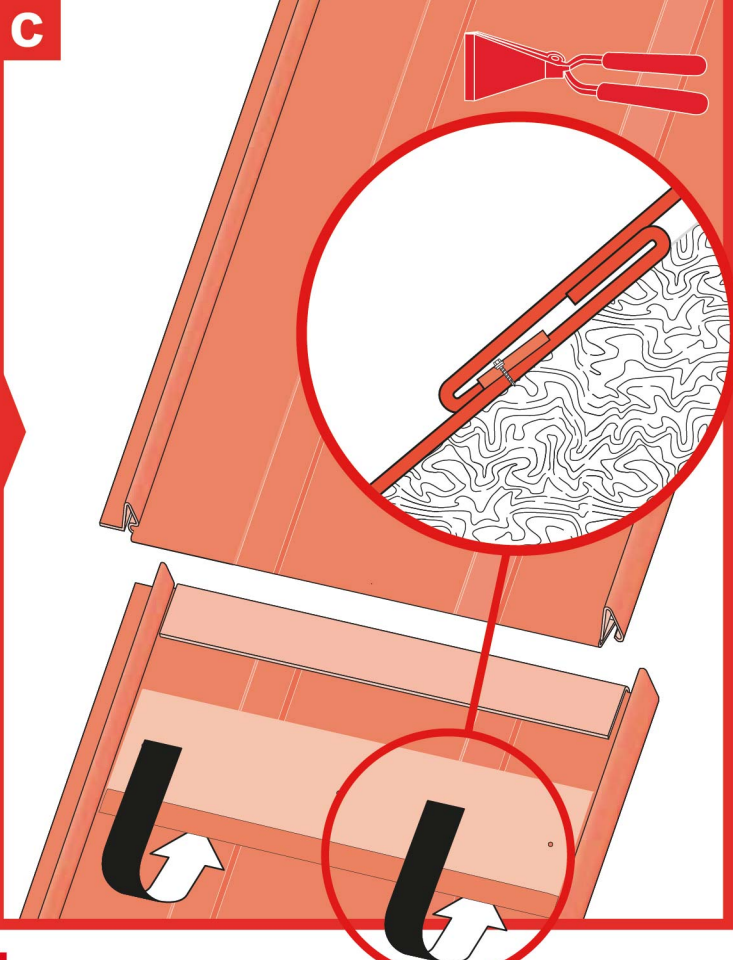

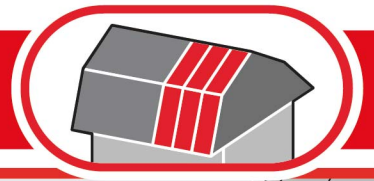

17

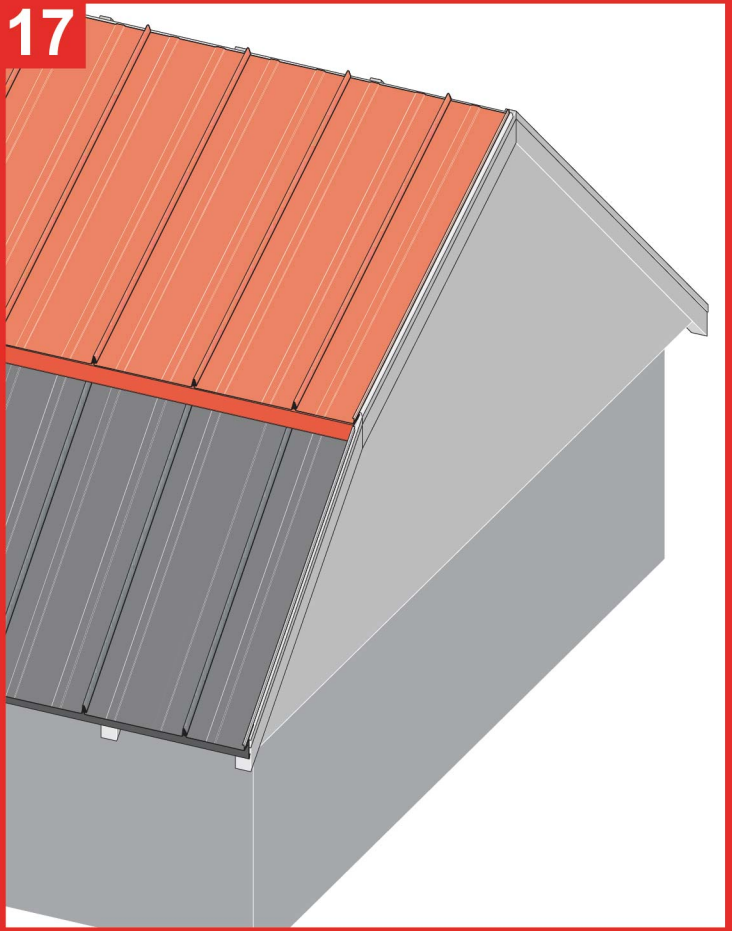

a

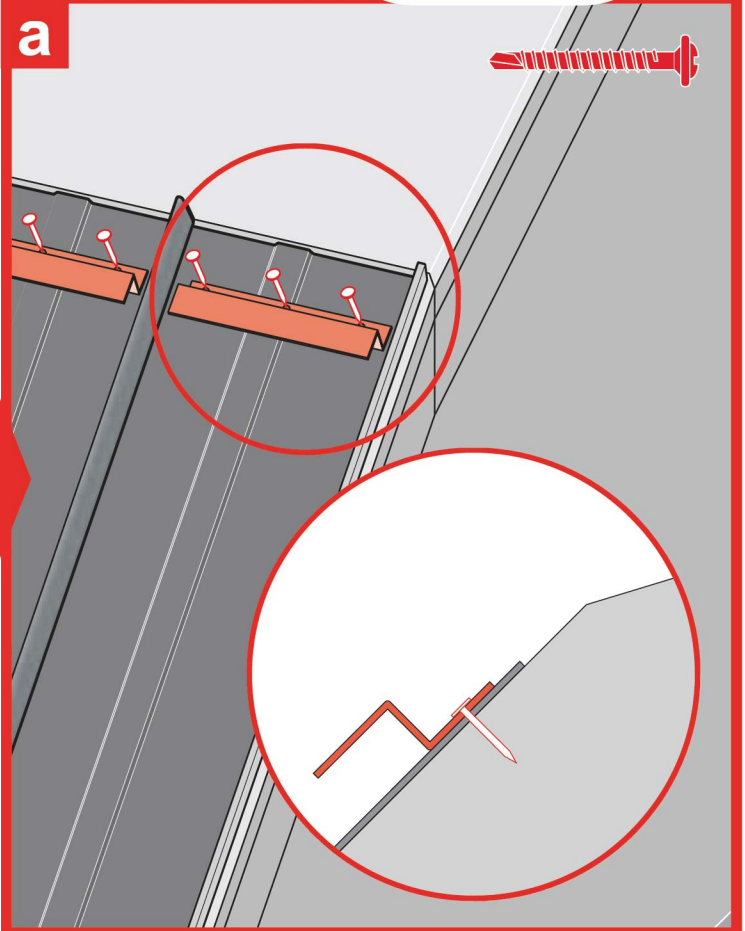

b

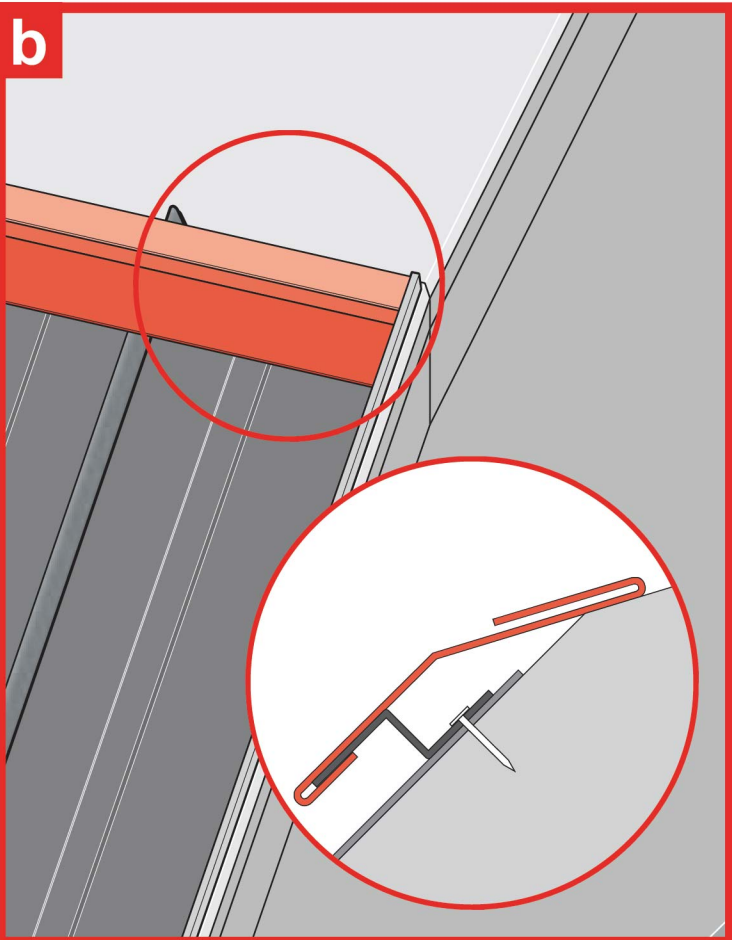

c

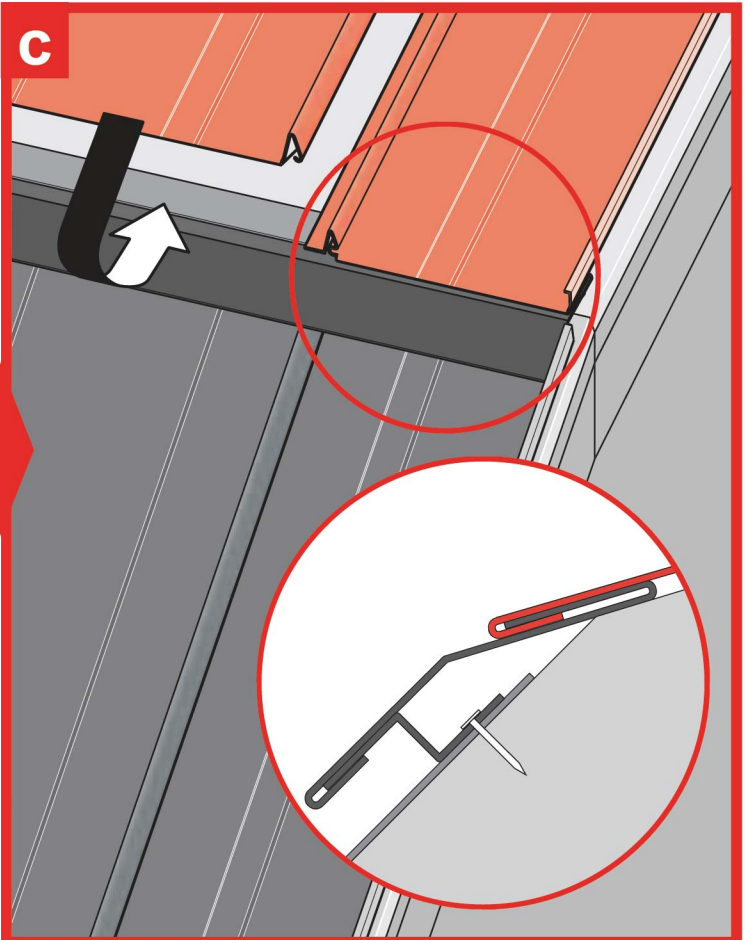

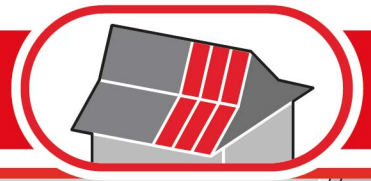

18

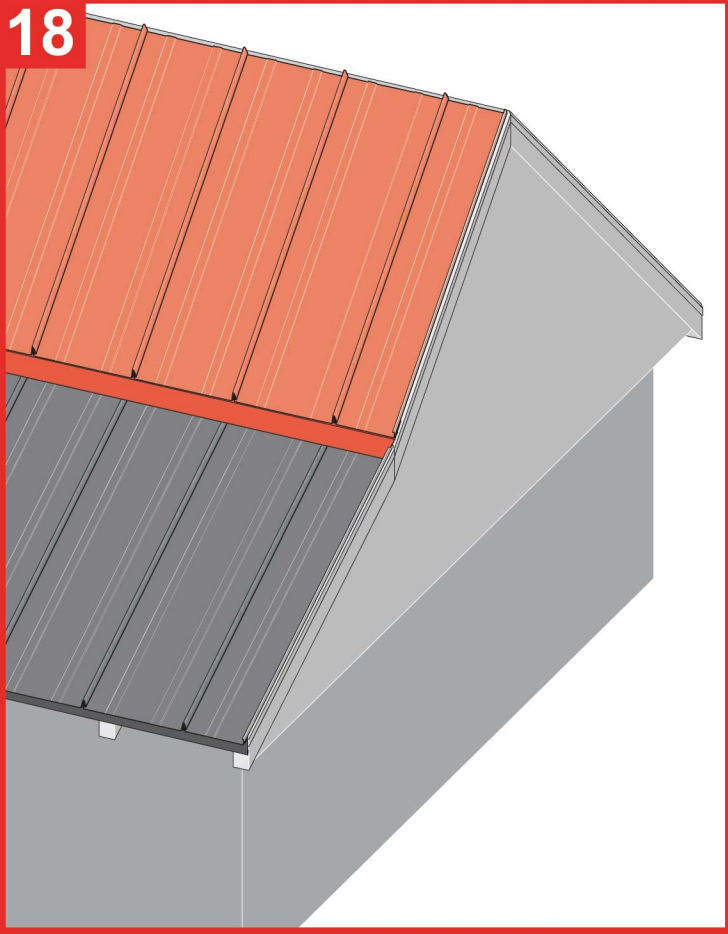

a

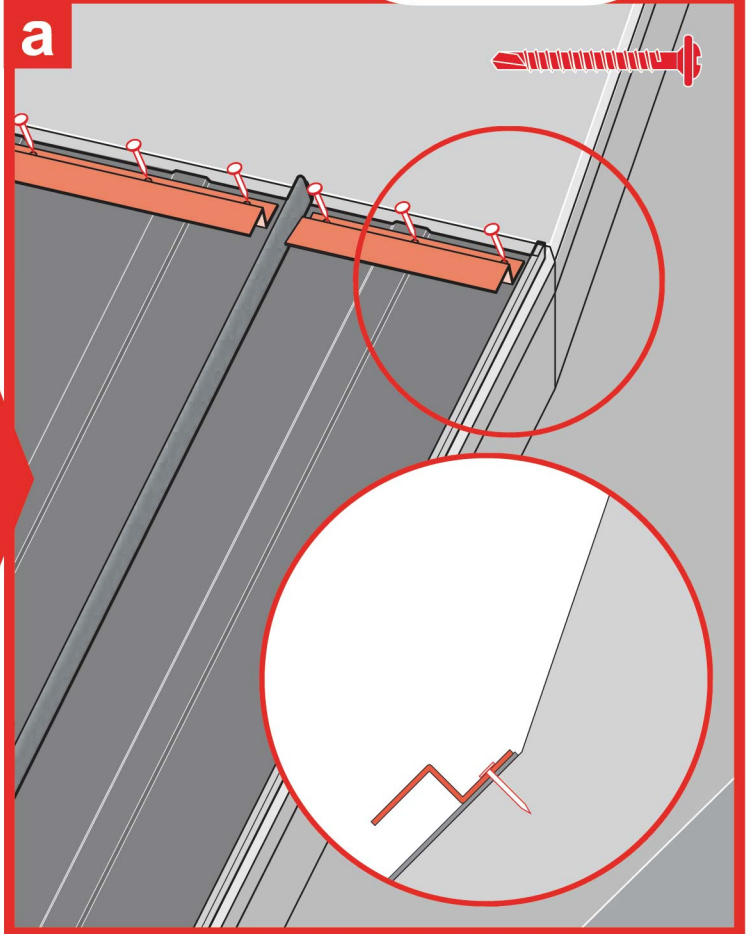

b

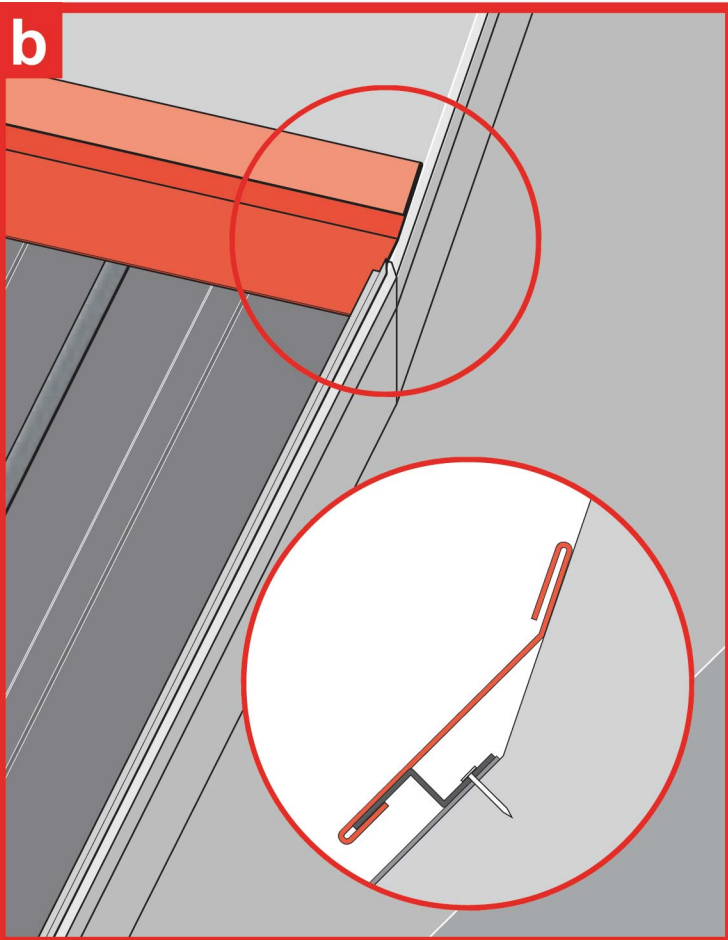

c

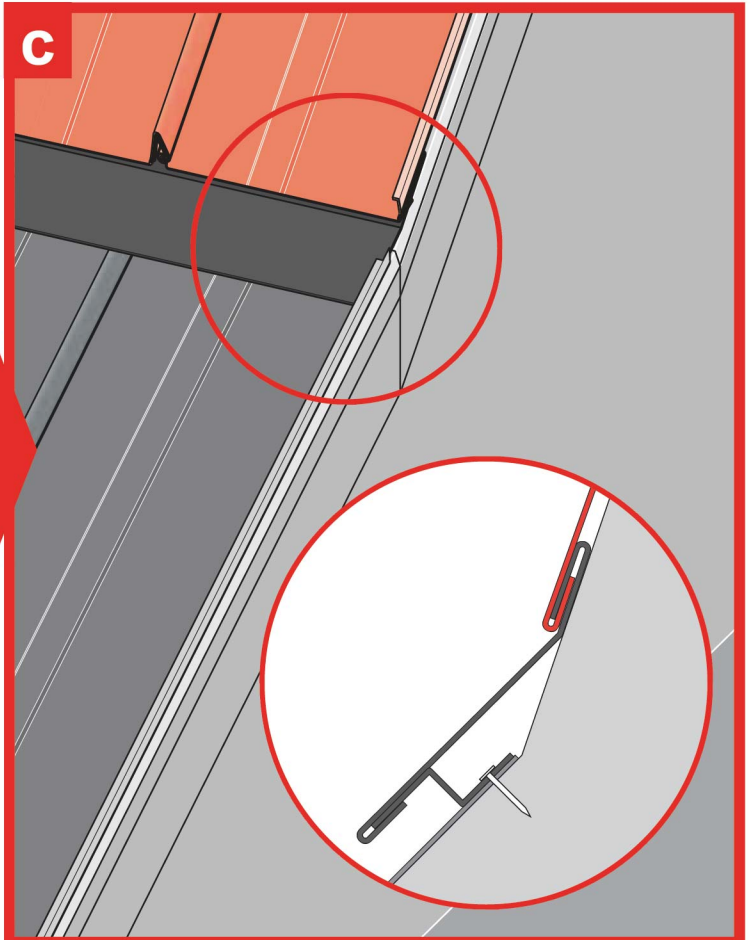

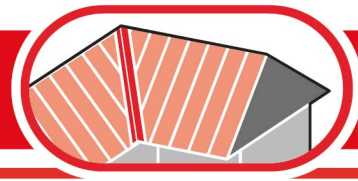

19

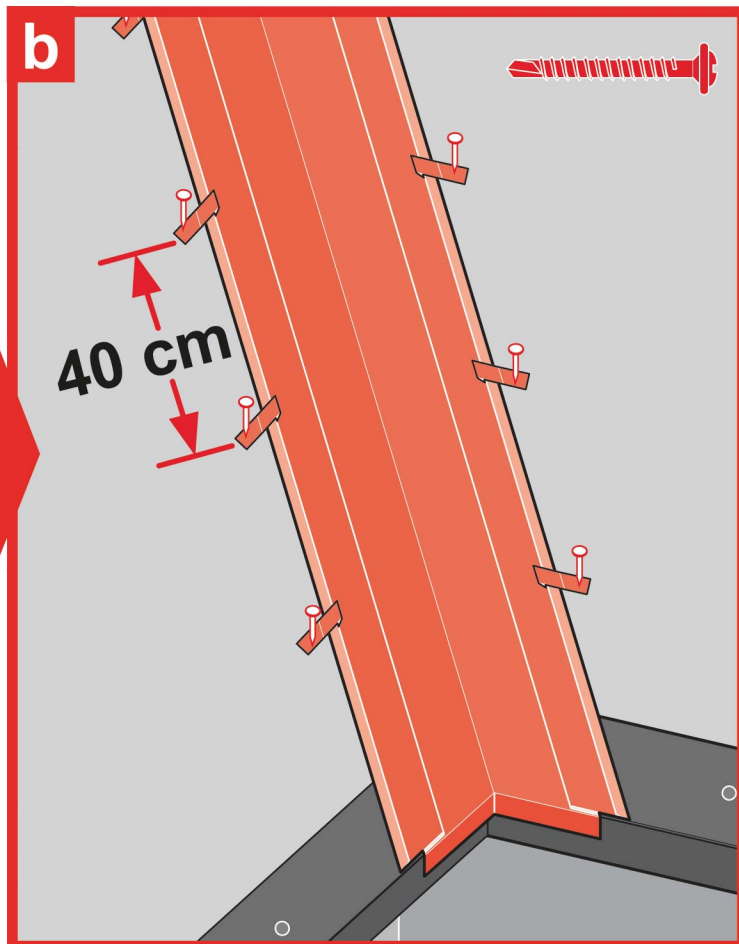
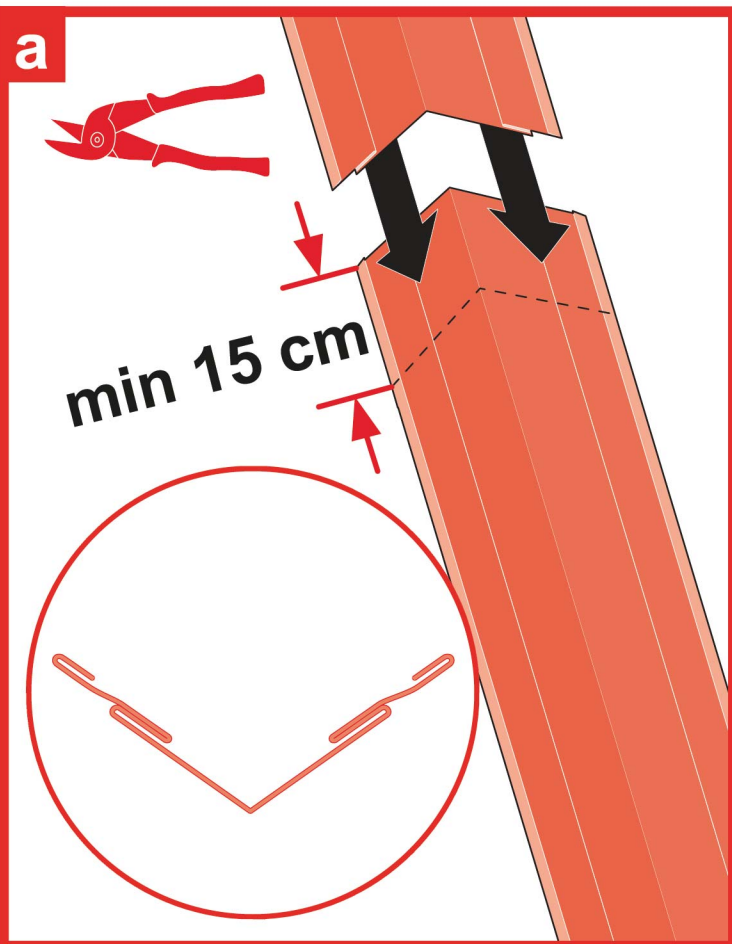
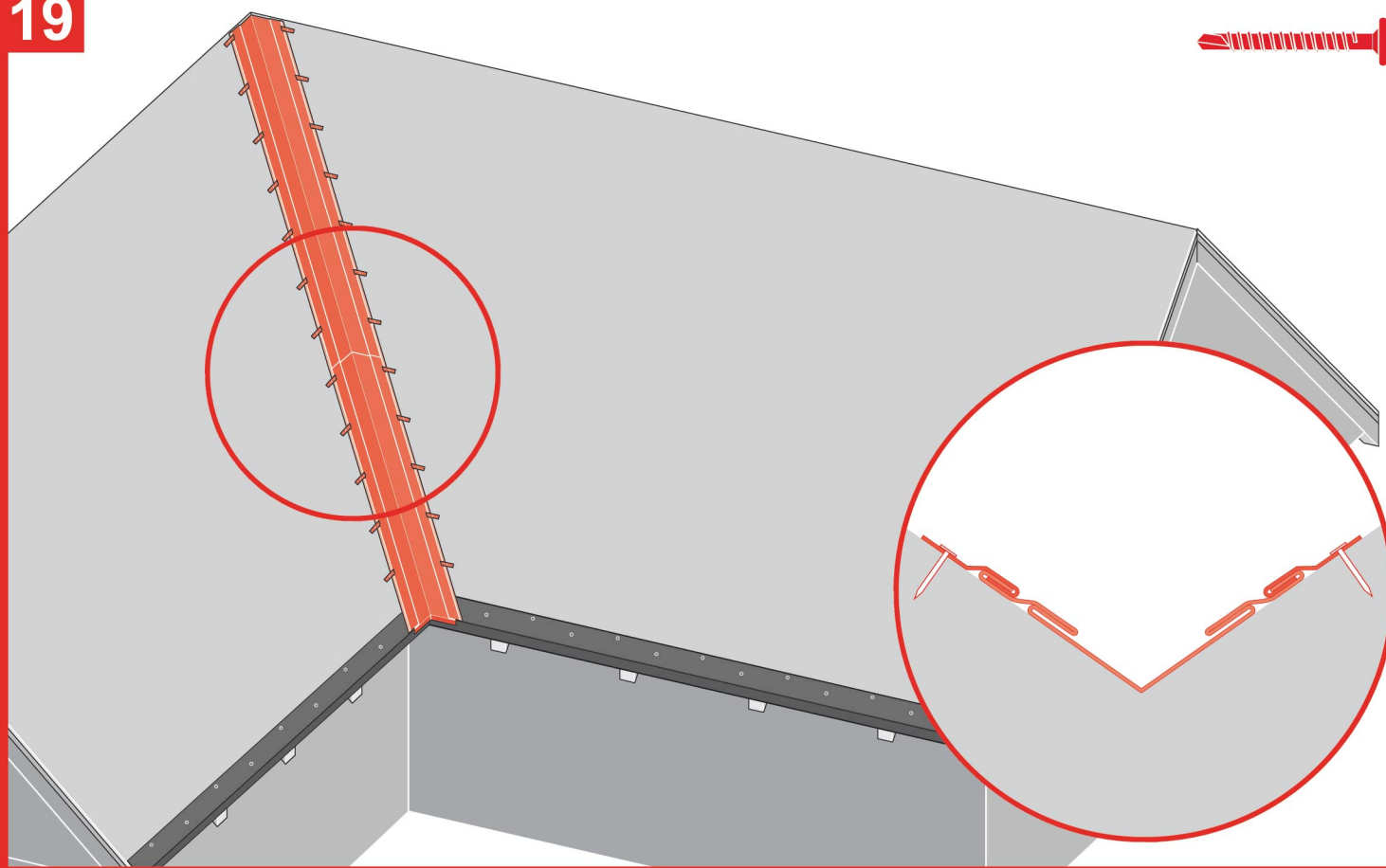

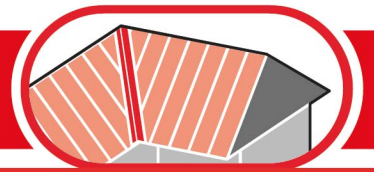

20

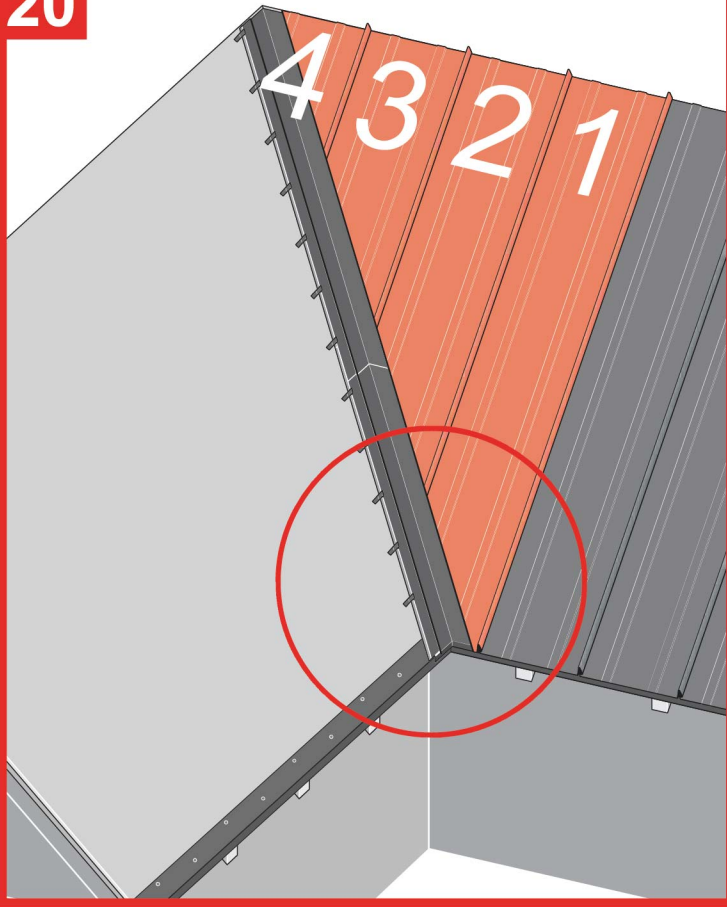

a

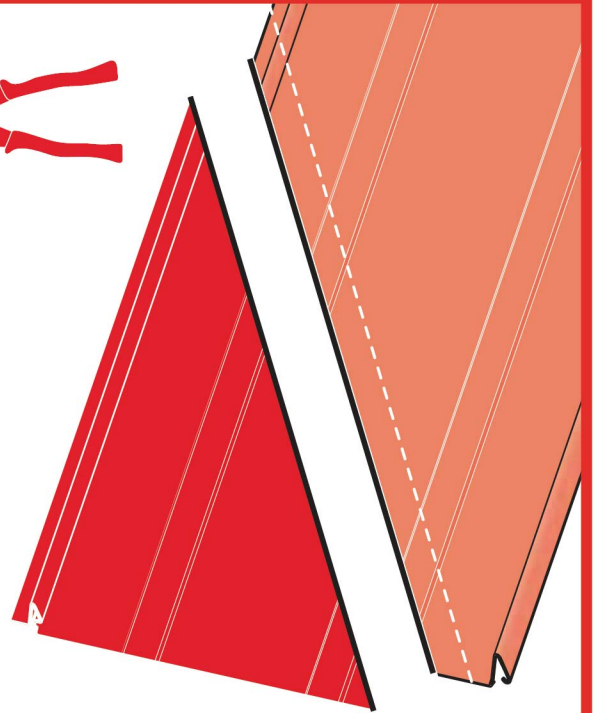

b

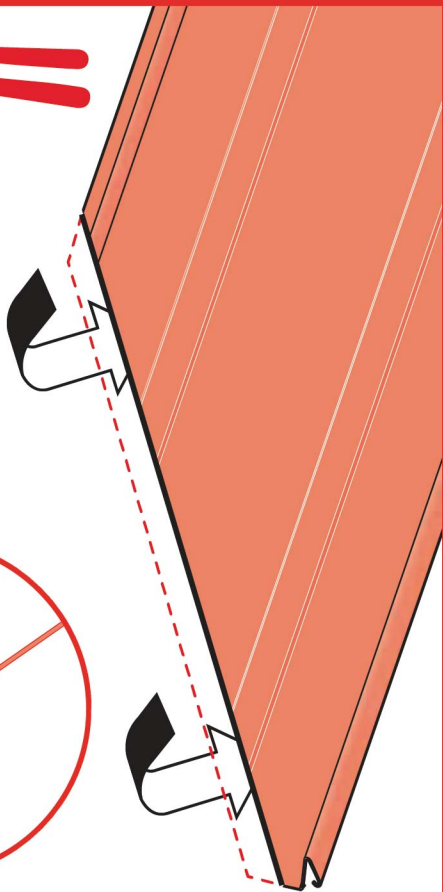
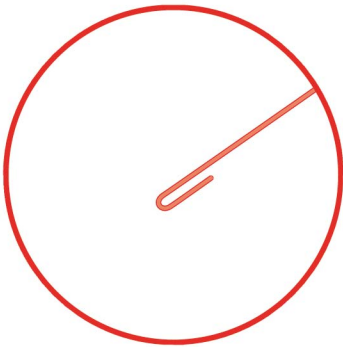

c

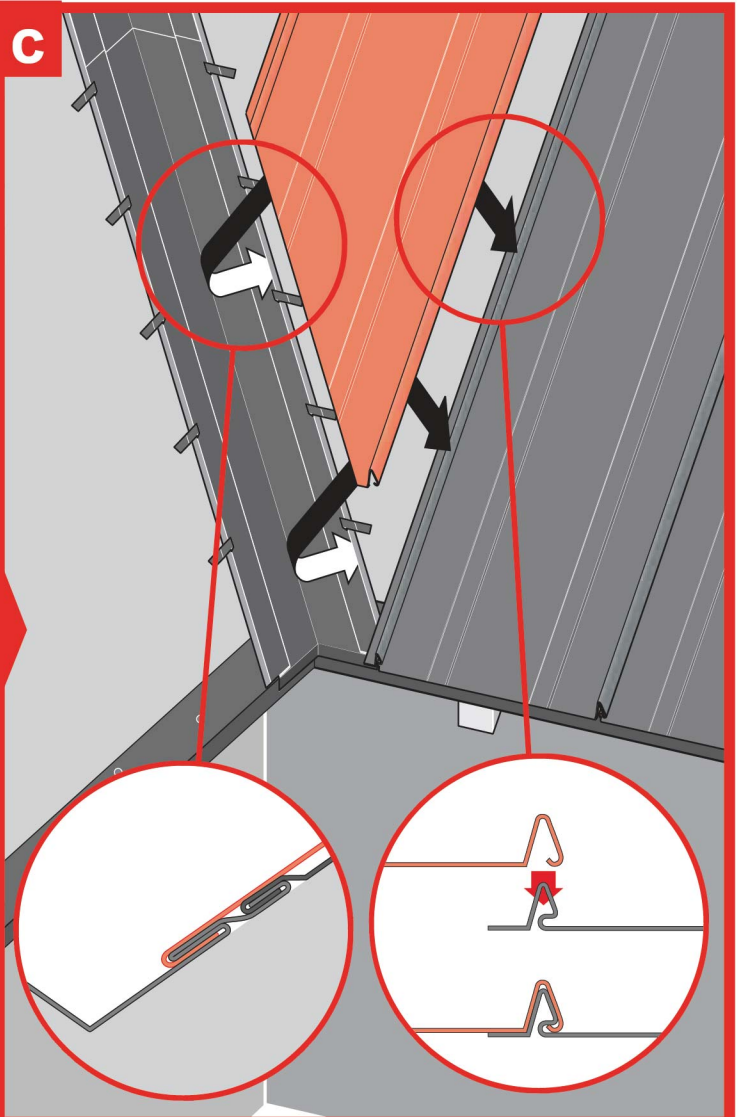

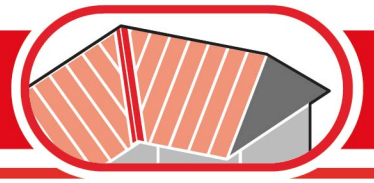

21

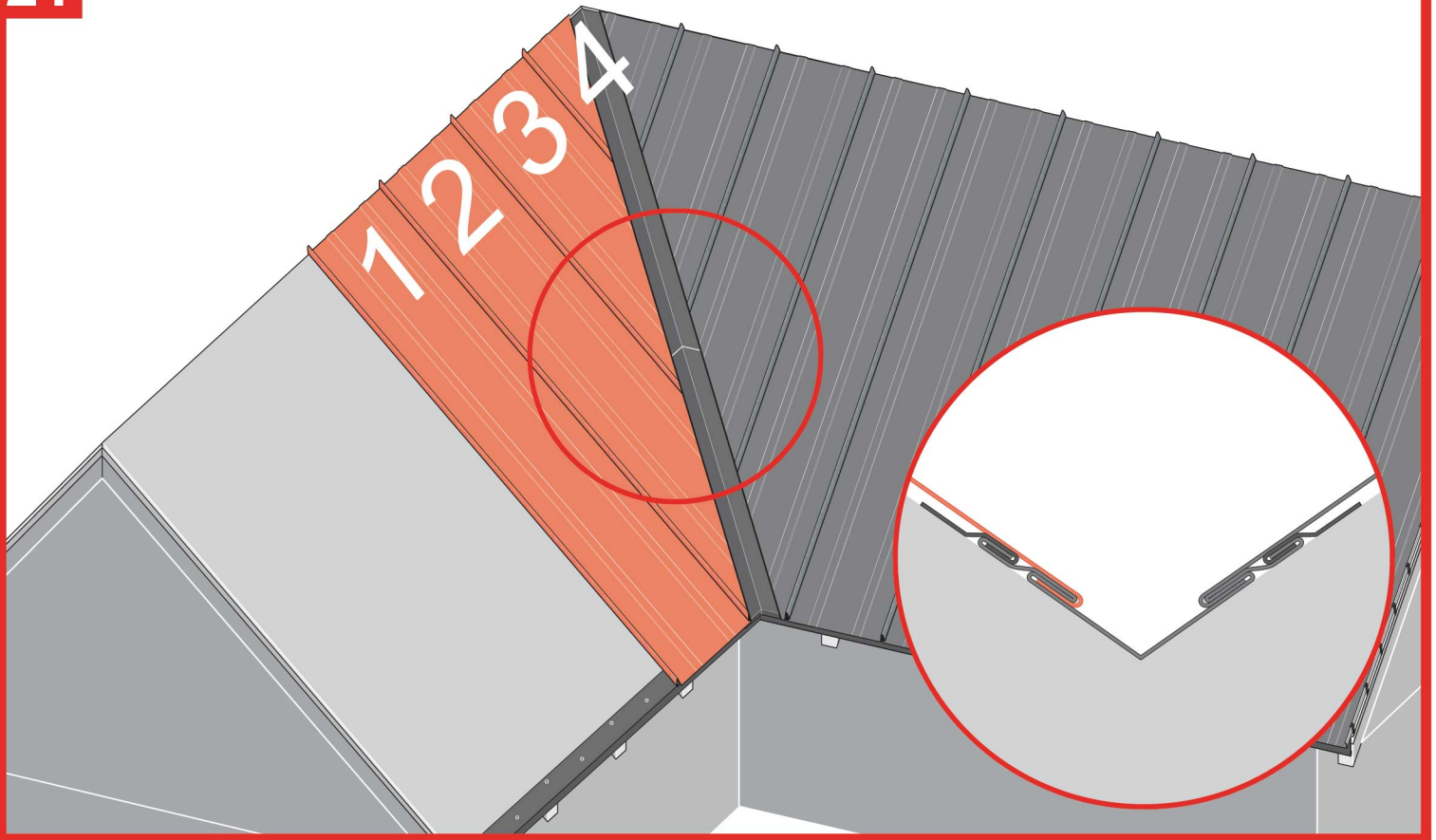

a

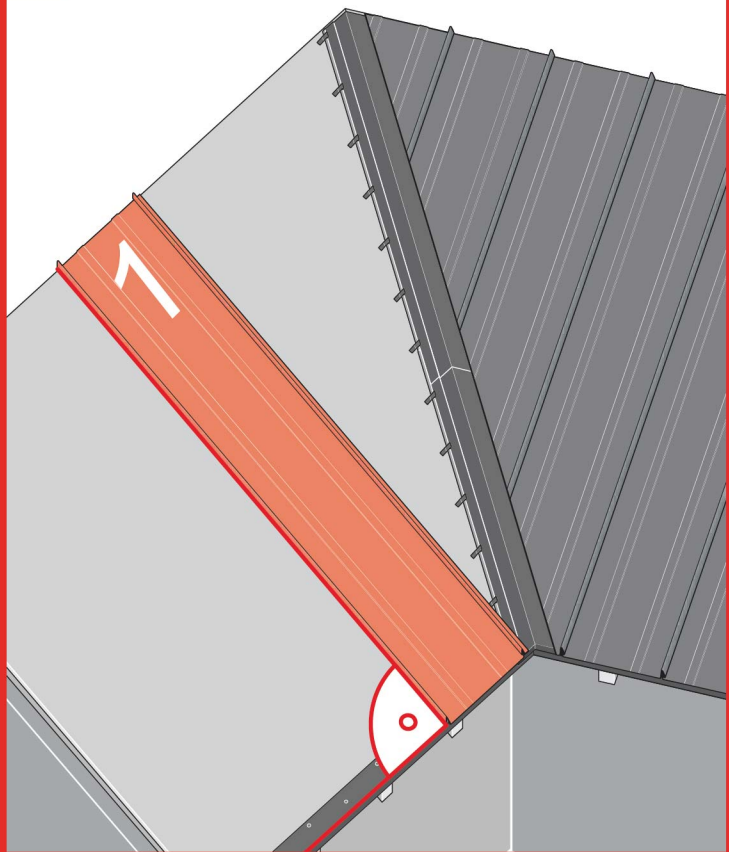

b

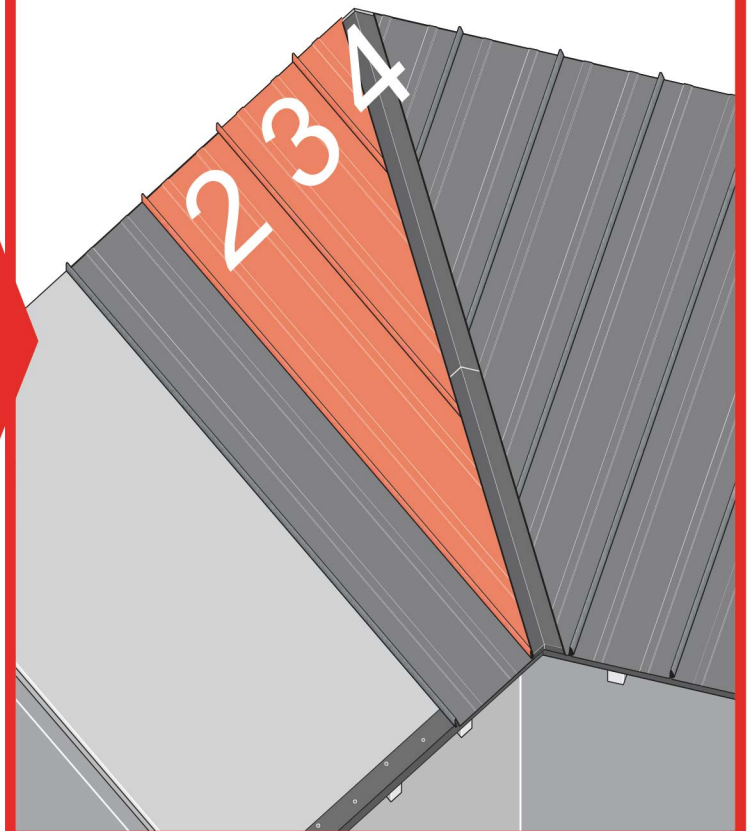

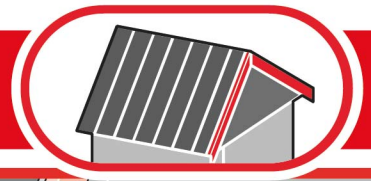

22

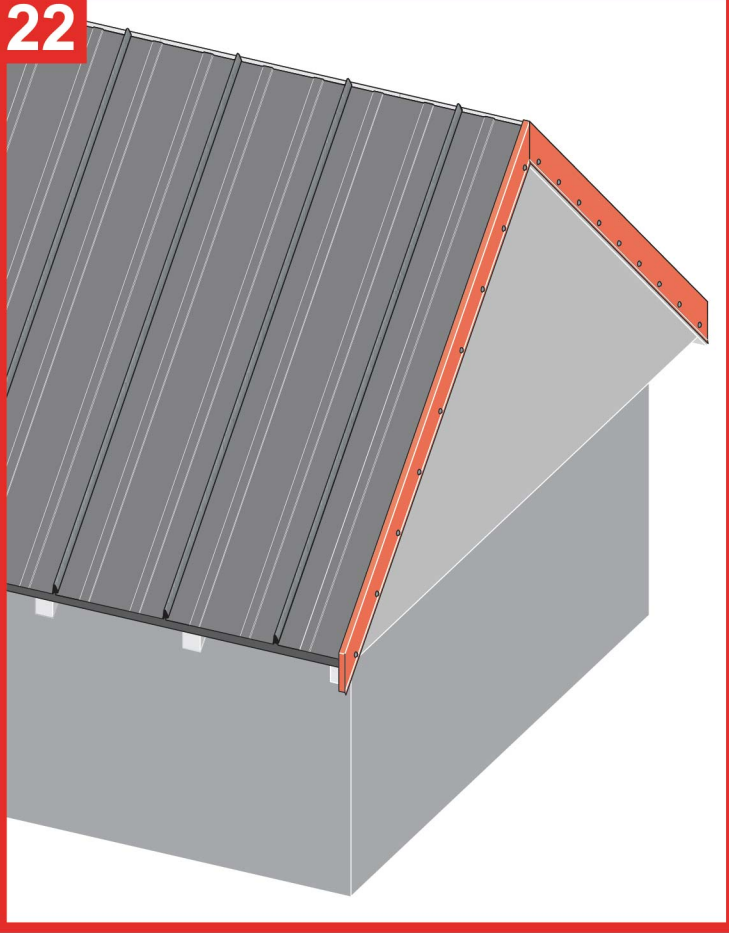

a

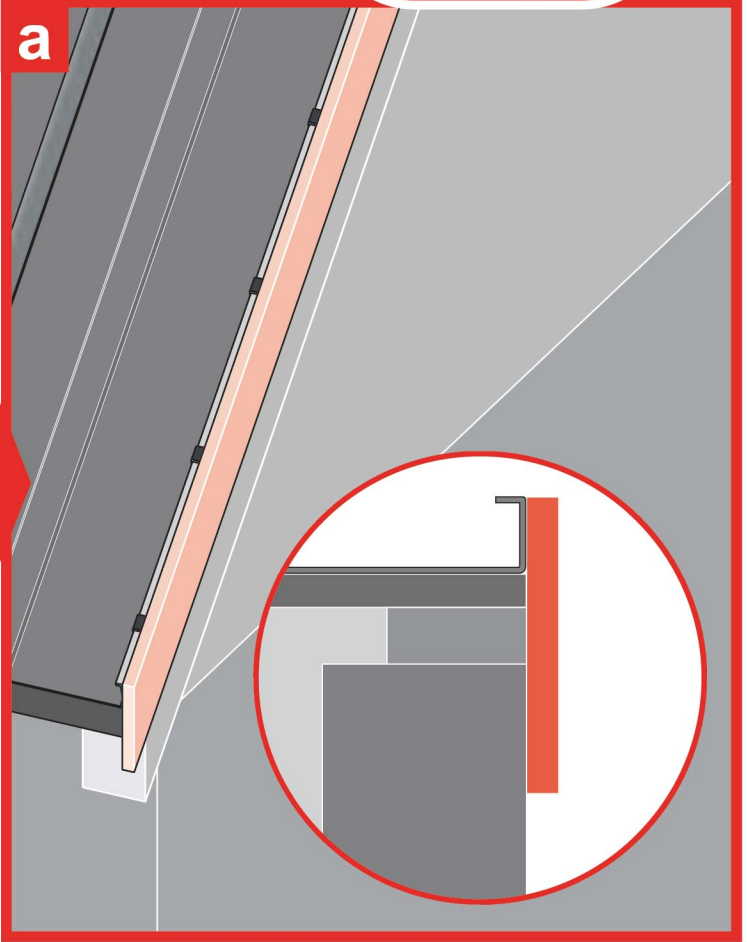

b

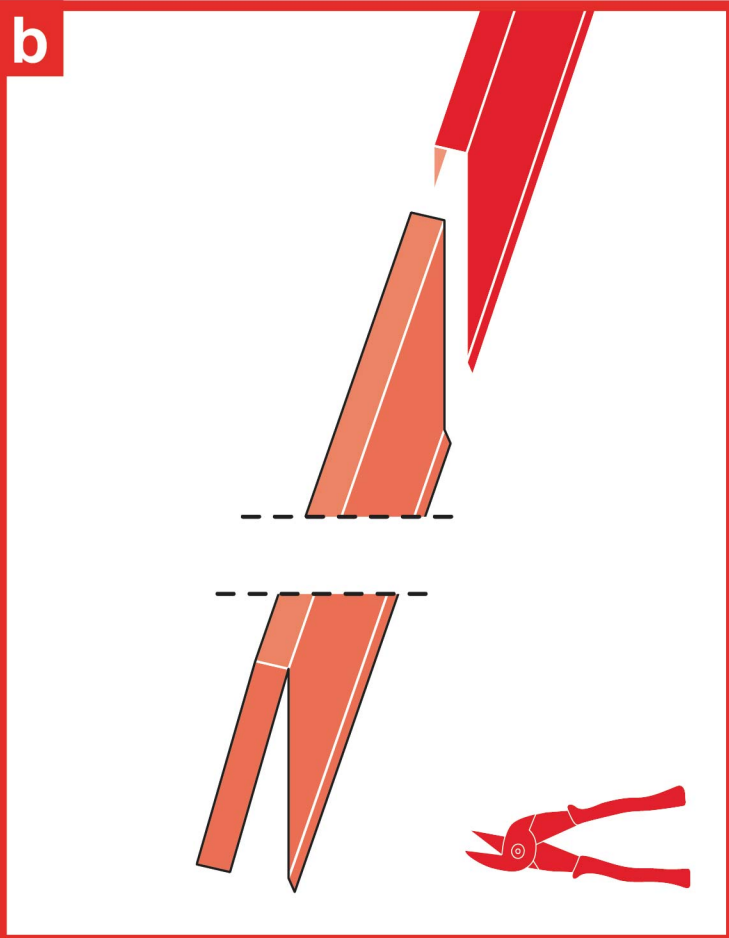

c

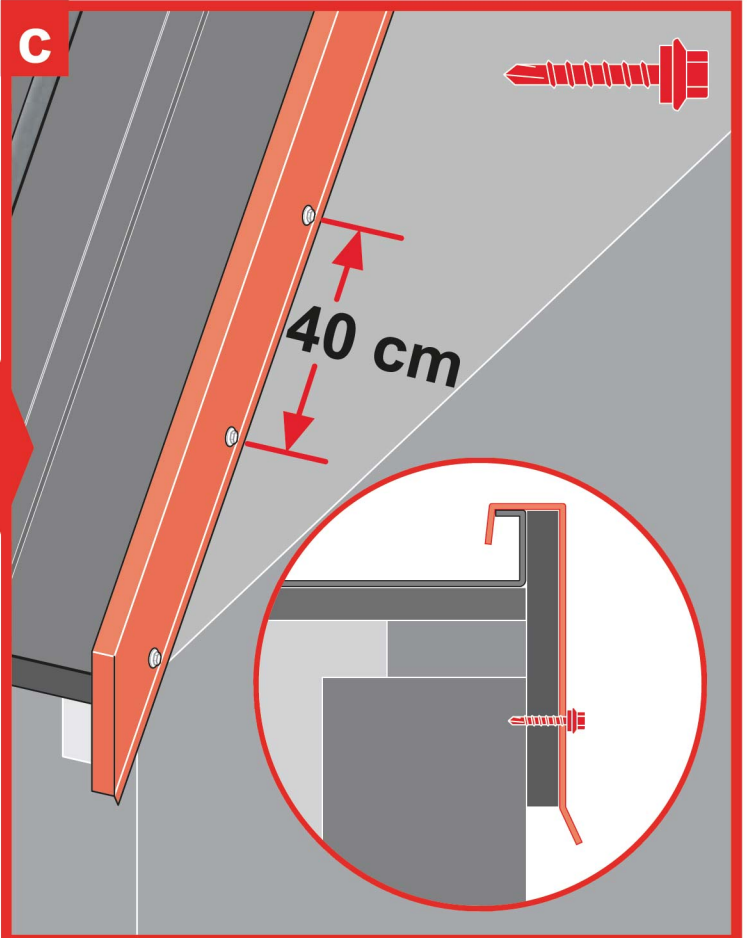

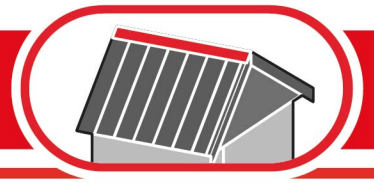

23

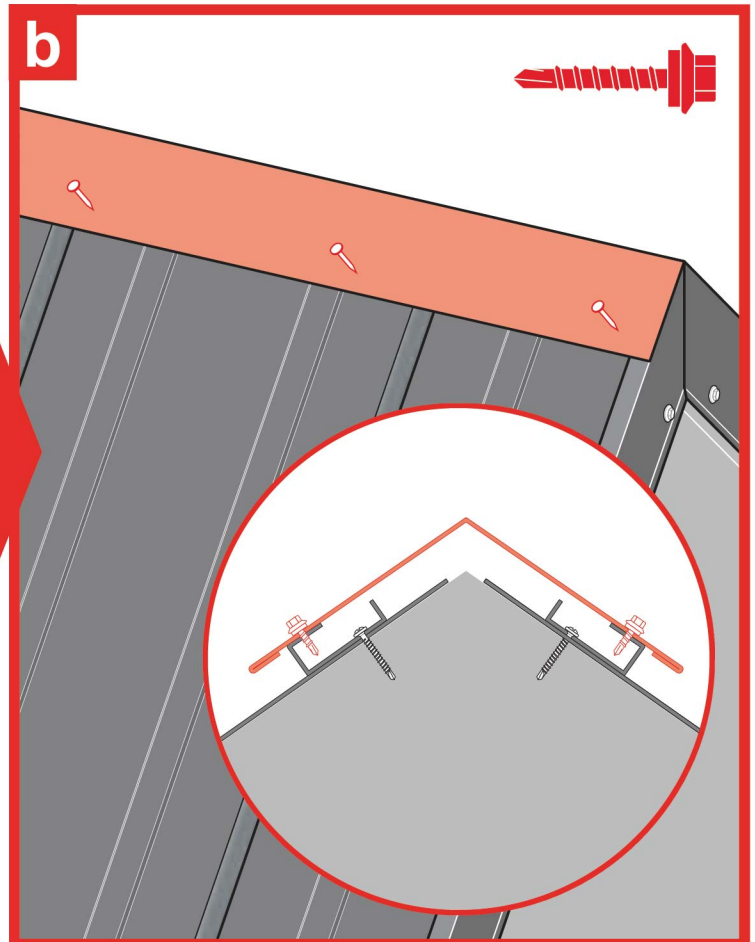
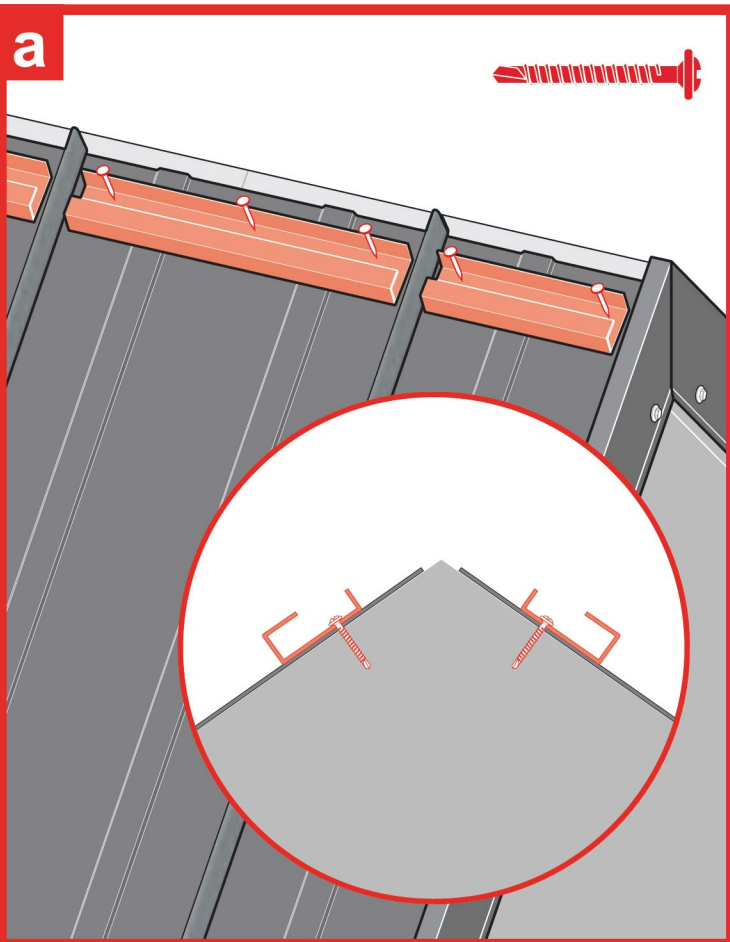
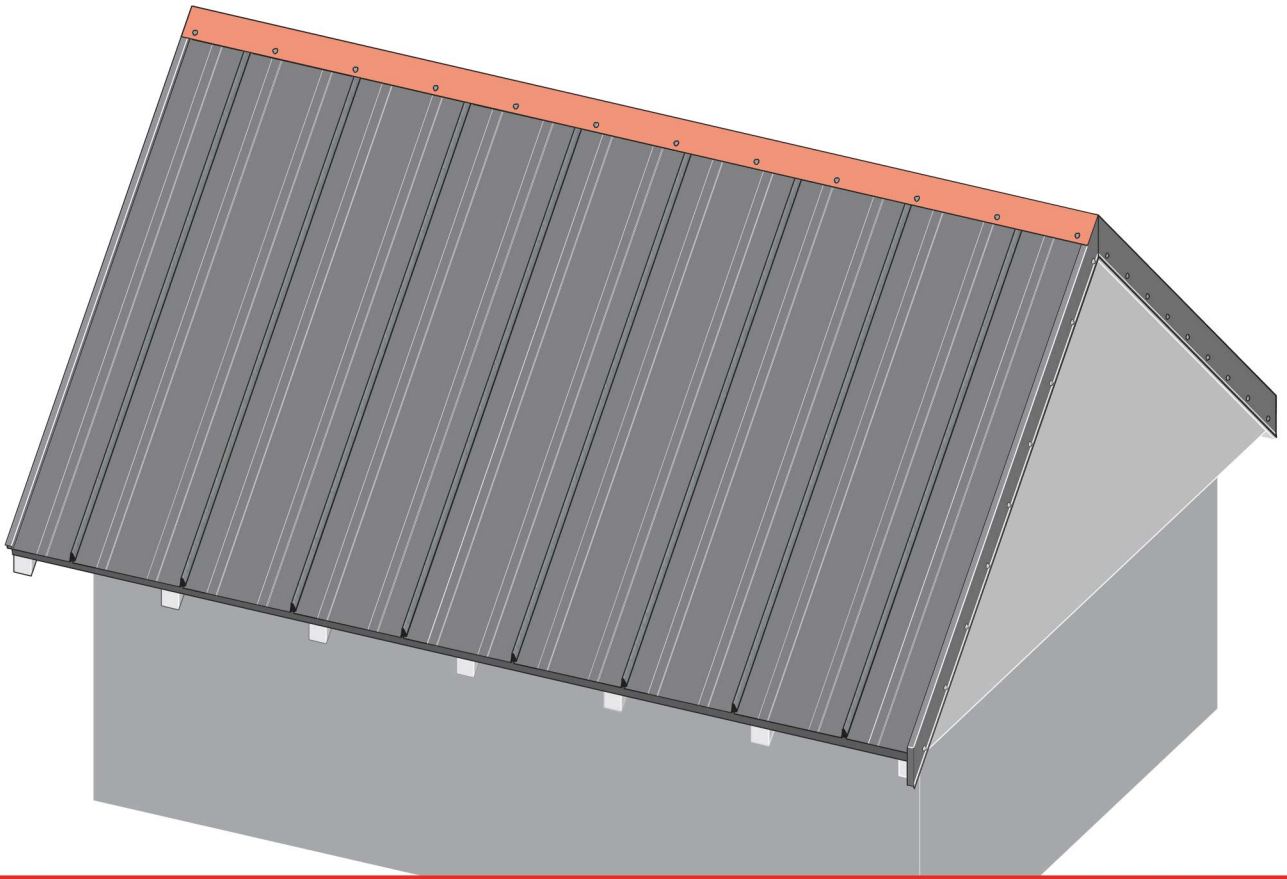

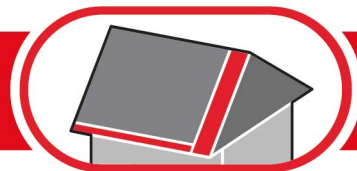

Cechy produktu i zalecenia

Wybierając pokrycie panela dachowego na rąbek stojący należy pamiętać, że efekt fałdowania (wypuklenia) na zainstalowanym dachu jest zjawiskiem naturalnie występującym w pokryciach płaskich. Wynika to z technologii produkcji i montażu blachy panelowej, z jej rozszerzalności termicznej oraz efektu odbicia światła. W zmiennych warunkach pogodowych - głównie wietrznych, może wystąpić również efekt słyszalnego falowania blachy. Nie wpływa to jednak na obniżenie jakości produktu, lecz wynika to z cechy produktu i metody jego krycia. W celu zmniejszenia tego efektu można zastosować dodatkowo: matę strukturalną, taśmę wygłuszającą lub oplot strukturalny (stosowany na papę).

UWAGI DOTYCZĄCE MONTAŻU PRODUKTU Z FILCEM ANTYKONDENSACYJNYM

W celu zapobiegania podciąganiu kapilarnemu na łączeniach poprzecznych arkuszy blach oraz nad okapem, antykondensat należy opalić opalarką gazową bądź elektryczną w odległości ok 25-35 cm ruchem płynnym posuwistym - tak, aby nie doprowadzić do miejscowego przegrzania blachy. Zabieg ten ma za zadanie opalić (zeszklić) powierzchnię powłoki antykondensatu, dzięki czemu nie będzie ona narażona na podciąganie wilgoci oraz promienie UV. Wymagana min. temperatura to 230 stopni C, ponieważ w tej temperaturze poliester zaczyna się topić. Należy również zachować ostrożność podczas transportu arkuszy na dach, aby nie uszkodzić antykondensatu o krawędź dachu, łąt, czy obróbkę blacharskich, by w trakcie eksploatacji materiał nie odklejał się od blachy. Zobacz więcej: <https://www.regamet.pl/do-pobrania/>



Niniejsza instrukcja jest materiałem poglądowym i nie zwalnia wykonawców z obowiązku przestrzegania zasad sztuki dekarzkiej oraz stosowania się do norm budowlanych. Sposoby montażu przedstawione w tej instrukcji mają charakter wskazówek ogólnych, dlatego różnice w doborze odpowiedniej metody, mogą wynikać z różnego rodzaju dachu i metod krycia w regionie zwłaszcza w przypadku blach nie posiadających rowka kapilarnego, które to mogą wymagać podczas montowania na dachu, dodatkowego uszczelnienia np. taśmą butylową, celem zapobiegnięcia kapilarnemu podciąganiu wody. Montaż blach dachowych wymaga fachowej wiedzy, praktyki i specjalizacji, dlatego doświadczeni wykonawcy posiadają indywidualne rozwiązania, które firma REGAMET aprobuje.